

**Grade : 3**

Mathematics Laboratory in Primary  
& Upper Primary schools





# ACTIVITY 1

To draw the following figures on a dot paper:  
 (i) a hut (ii) a joker (iii) a flower

**Learning Objective :** To handle ruler and pencil and to identify straight lines, curves and closed figures.

**Pre-requisite :** Knowledge of horizontal, vertical and slanting lines and familiarity with dot papers.

**Materials required :** A dot Paper, a pencil, an eraser and a ruler

**Procedure :** (i) Drawing a hut

**Step 1.** Mark or identify a dot in the dot paper.

**Step 2.** Starting from this dot as first, using pencil and ruler, draw a horizontal line upto the sixth dot towards right [Fig. 1(a)].

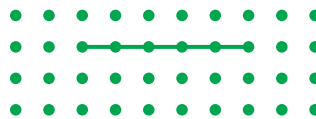

Fig. 1(a)

**Step 3.** From both ends of this line, draw vertical lines downward covering 4 dots [Fig. 1(b)].



Fig. 1(b)

**Step 4.** Using a ruler join the lower ends of the vertical lines to get a four-sided closed figure [Fig. 1(c)].

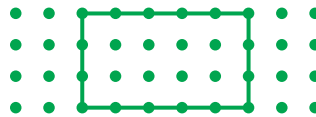

Fig. 1(c)

**Step 5.** Proceed further to complete the figure of a hut by drawing horizontal, vertical and slanting lines.

**Repeat above steps to draw**

(i) A joker (ii) a flower

**Observations : Observe each of the figures and note down**

- (i) Number of horizontal lines = .....
- (ii) Number of vertical lines = .....
- (iii) Number of slanting lines = .....
- (iv) Number of curved lines = .....
- (v) Number of triangles = .....
- (vi) Number of rectangles = .....
- (vii) Number of squares = .....
- (viii) Number of circles = .....



**ACTIVITY 2**

To represent the following pairs of numbers on straight lines using stickers and to identify the greater number from the representation.

(i) 7 and 11 (ii) 9 and 5

**Learning Objective** : To compare numbers

**Prerequisite** : Knowledge of numbers.

**Materials required** : Two sheets of paper and 40 identical stickers.

**Procedure** : Representing numbers 7 and 11 on straight lines

**Step 1.** Draw two straight lines on a paper sheet [Fig. 2(a)].

**Step 2.** Take seven stickers and stick them one by one on the first line starting from one end. Make sure no gap is left between any two stickers and also no two stickers overlap each other [Fig. 2(b)].

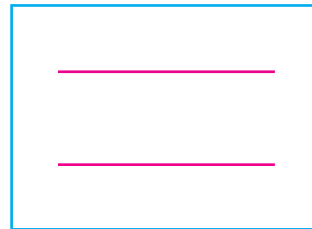

Fig. 2(a)



Fig. 2(b)

**Step 3.** Now take 11 stickers and stick them one by one on the second line in the same way as above [Fig. 2(c)].

**Step 4.** Observe the lengths of the stickers and note down that the number representing longer length of the stickers, is greater than the other.

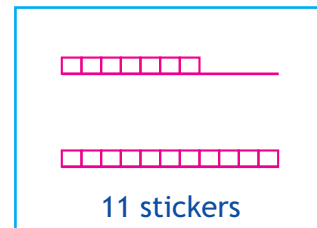

Fig. 2(c)

Similarly represent numbers 9 and 5 using stickers and note down the number representing longer length of the stickers.

**Observations :**

Comparing the lengths of the stickers

- (i) In the activity (i) greater number is .....
- (ii) In the activity (ii) greater number is .....

**Extension of the activity :** This activity may also be performed by shading squares in a line on the grid paper.

## ACTIVITY 3

To measure the following :

- (i) Length of right palm (ii) Width of right palm  
(iii) Length of right ear (iv) Width of smile  
by group activity using a ruler/a measuring tape.

**Learning Objective :** (i) To develop the measuring skill  
(ii) To collect, display and interpret the data

**Pre-requisite :** Knowledge of using a ruler or a measuring tape.

**Materials Required :** A ruler / measuring tape, a pencil and a paper.  
(Activity is to be performed by a group of 4 or 6 students)

**Procedure :** Measurement of length and width of the right palm.

**Step 1.** One student stretches the palm of his right hand and another student in the group measures the length and width of the palm using a ruler or measuring tape and records the observation.

**Step 2.** Now, the two students interchange their roles.

**Step 3.** All members in the group follow the same procedure in pairs.

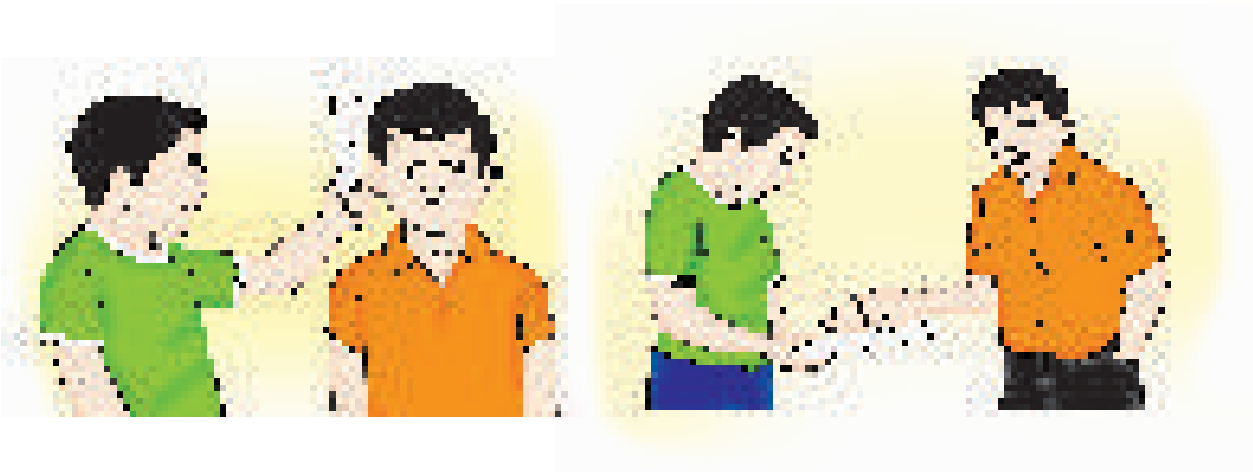

### Measuring length of the right ear

**Step 1.** One student holds a ruler parallel and close to the right ear of another student and measures the length of his/her ear.

**Step 2.** Now the two students interchange their roles.

**Step 3.** Other members of the group in pairs follow the same procedure.





### Measurement of width of the smile

- Step 1.** All the students help each other in measuring the width of ones smile using a measuring tape or a scale.
- Step 2.** It should be ensured that the ruler or measuring tape remains in contact with the skin while making measurement
- Step 3.** All the members of the group record the observations.

### Observation

Student Name	Length of the right palm	Width of the right palm	Length of the right ear	Width of the smile

- Group member having longest palm length .....
- Group member having shortest palm length .....
- Group member having widest smile .....
- Group member having longest ear .....
- Group member having shortest ear .....

## ACTIVITY 4

*To measure the dimensions of the floor of a room in the house using 1m long thick string.*

**Learning Objective :** To estimate and measure large lengths.

**Pre-requisite :** Knowledge of measuring length and its unit.

**Materials required :** Thick string, a metre scale, a pencil or a piece of chalk.

**Procedure :**

**Step 1.** Cut a piece of string 1m long using a metre scale.

**Step 2.** Place one end of the 1m string at one of the corners of the floor and stretch, keeping it straight along one side of the floor. [Fig. 4(a)]

**Step 3.** Mark the position of the other end of the string on the floor with a piece of chalk or pencil.

**Step 4.** Remove the string from this position and place it again away from the corner along the side of the floor keeping its one end at the marked position.

**Step 5.** Mark the position of the other end of the string on the floor. [Fig. 4(b)]

**Step 6.** Proceed further in the same way and complete the measurement of this side of the floor, considering lengths (if needed) smaller than 1 m as  $\frac{1}{2}$  m or  $\frac{1}{4}$  m by folding the string.

**Step 7.** Record your observations.

Similarly measure the lengths of other sides of the floor and record your observations. Follow the same process to measure the dimensions of floor of other rooms in your house.

**Observations :**

Room Number .....

Length of the 1st side .....

Length of the 2nd side .....

Length of the 3rd side .....

Length of the 4th side .....

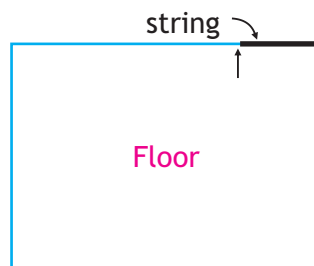

Fig. 4(a)

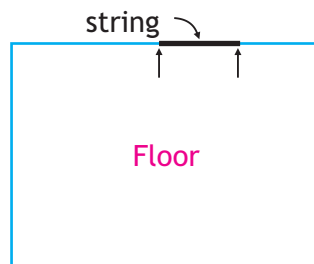

Fig. 4(b)







Observations :

S.No.	Name of the object	Total number of edges	Total number of corners
1			
2			
3			
4			
5			



## ACTIVITY 5 B

*To record the number of edges and corners obtained after folding a rectangular sheet of paper from each corner one by one.*

**Learning Objective** : To identify edges and corners of different objects.

**Pre-requisite** : Knowledge of edges and corners.

**Material required** : One rectangular sheet of paper.

**Procedure** :

**Step 1.** Take a rectangular sheet of paper and observe that it has four corners. Mark them as 1, 2, 3 and 4. Clearly it has 4 edges.

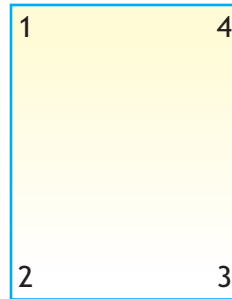

**Step 2.** Fold one of the corners of the rectangular sheet and observe the new shape of the sheet. [Fig. 5(b)(1)]

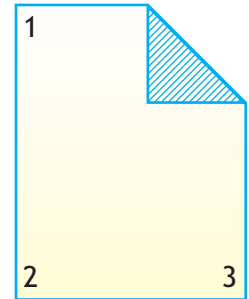

Fig. 5(b)(1)

**Step 3.** Count the number of edges and corners of the new shape of the sheet.

**Step 4.** Record the observations.

**Step 5.** Fold the second corner of the sheet and observe the new shape of the sheet. [Fig. 5(b)(2)]

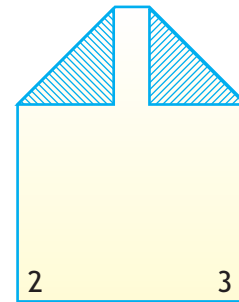

Fig. 5(b)(2)

**Step 6.** Count the number of edges and corners of the new shape after folding two corners.

Similarly count the number of corners and edges after folding 3rd and 4th corner.

**Observations :**

Shape	Number of edges	Number of corners
Rectangle		
After folding 1st corner		
After folding 2nd corner		
After folding 3rd corner		
After folding 4th corner		

# ACTIVITY 5 C

*To observe the number of edges and corners in the shape formed by creases selected after folding a rectangular sheet of paper 5 times and then unfolding it.*

**Learning Objective :** To identify edges and corners in a given shape.

**Pre-requisite :** Knowledge of edges and corners.

**Materials required :** A rectangular sheet of paper.

**Procedure :**

- Step 1.** Take a rectangular sheet of paper and fold it parallel to its breadth near the middle of the paper to get a crease. [Fig. 5c(1)]
- Step 2.** Now fold the folded paper again along the length near the middle to get another crease. [Fig. 5c(2)]
- Step 3.** Similarly for 3rd, 4th and 5th fold follow the directions given in Fig. 3 to 5
- Step 4.** Unfold all the five folds of the paper
- Step 5.** Select and draw any one closed shape formed by creases.
- Step 6.** Record the number of edges and corners of the shape drawn.

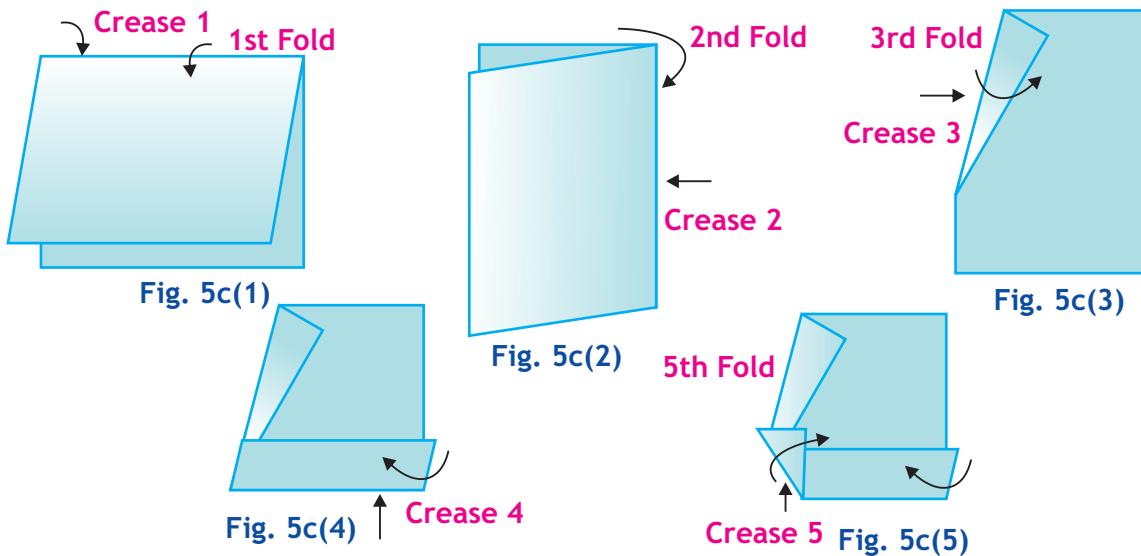

**Observations :**

Number of edges in the selected shape .....

Number of corners in the selected shape .....



**ACTIVITY 6**

To make the following shapes using set of Tangram cutouts:

- (i) a cat      (ii) numeral 4

**Learning Objective :** To explore different shapes using given geometrical shapes.

**Pre-requisite :** Knowledge of geometrical shapes.

**Materials required :** Two sets of cut outs of the Tangram.

**Procedure :**

**Step 1.** Identify the different shapes of cut outs in a set of Tangram [Fig. 6(a)].

**Step 2.** Using all the seven cutouts of a Tangram set placing edge to edge with no space left in between, obtain the shape as in [Fig.6(b)].

**Step 3.** Proceed in the same way to obtain the shape shown in [Fig. 6(c)].

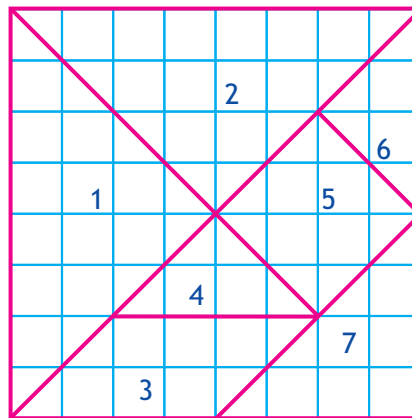

Fig. 6(a)

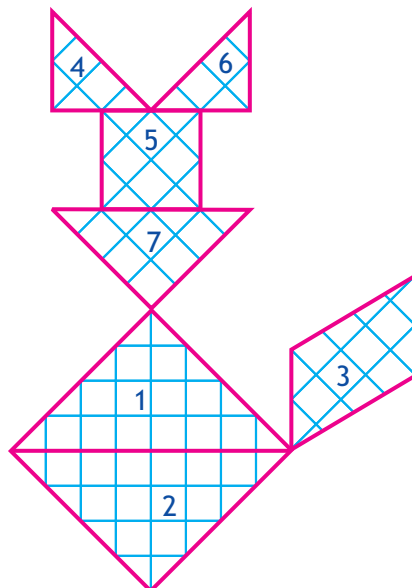

Fig. 6(b)

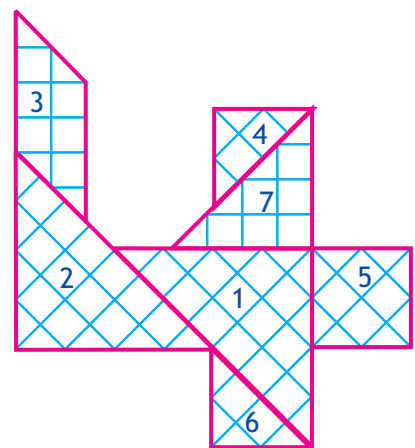

Fig. 6(c)

**Observations:**

1. Figure in 6(b) looks like .....
2. Figure in 6(c) looks like .....

**Extension :** Try to get the shape of

- (i) a duck
  - (ii) a cat in some other posture
  - (iii) a man in sitting posture
- using all the seven pieces of Tangram set.





## ACTIVITY 7

To make a time table from wake up time to bed time on a

(i) working day      (ii) holiday

**Learning Objective :** To understand the importance of time and planning.

**Pre-requisite :** Knowledge of reading time from the clock.

**Materials required :** A pencil and a sheet of paper.

**Procedure :**

**Step 1.** Keeping the time interval of one hour, record the time intervals and the corresponding activities performed on a working day (say Monday) in the table (I) as shown.

**Table-1**  
**Monday**

Time interval of 1 hour	Activity performed
(Morning) 6.00 O`Clock - 7.00 O`Clock	Getting ready to go to School
7.00 - 8.00	
8.00 - 9.00	

**Step 2.** Proceed in the same way to record your time and the activities performed on a holiday.

**Table 2**  
**Sunday**

Time interval of 1 hour	Activity performed
(Morning) 6.00 O`Clock - 7.00 O`Clock	Sleeping
7.00 - 8.00	
8.00 - 9.00	

**Observations :**

- (i) How much time do you spend on sleeping after 6 o'clock on a working day?  
.....
- (ii) How much time do you spend on a holiday for studying? .....
- (iii) For how many hours do you watch TV?
  - (a) on a working day .....
  - (b) on holiday .....
- (iv) For how many hours do you play?
  - (a) on a working day .....
  - (b) on holiday .....

**Extension :** Students can divide themselves in groups of 5 and can make a comparison in their study time and play time, among themselves.



**ACTIVITY 8**

*To represent multiplication tables of 2 and 3 using lines and dots.*

**Learning objective** : To visualize and understand multiplication tables.

**Pre-requisite** : Knowledge of horizontal and vertical lines and process of addition.

**Materials required** : A sheet of paper and bindies

**Procedure** :

**Step 1.** Draw two vertical lines as in the Fig. 8(a).

**Step 2.** Now draw a horizontal line intersecting the two vertical lines and paste bindies at the intersection representing  $2 \times 1 = 2$  [Fig. 8(b)].

**Step 3.** Again draw two vertical lines. Now draw two horizontal lines intersecting two vertical lines and paste bindies at the four points of intersection. These points represent  $2 \times 2 = 4$  [Fig. 8(c)]

**Step 4.** Repeat the above steps drawing 2 vertical lines and three horizontal lines, intersecting at six points. These points represent  $2 \times 3 = 6$  [Fig. 8(d)]

**Step 5.** Repeat the above steps with four horizontal lines intersecting the two vertical lines to represent  $2 \times 4 = 8$  as in [Fig. 8(e)].

**Step 6.** Continue the activity increasing the number of horizontal lines one by one upto ten and complete the multiplication table.

**Step 7.** Starting with three vertical lines and intersecting them by horizontal lines, as above obtain the multiplication table of 3 as shown in Fig. 8(f), Fig. 8(g) and Fig. 8(h).



Fig. 8 (a)

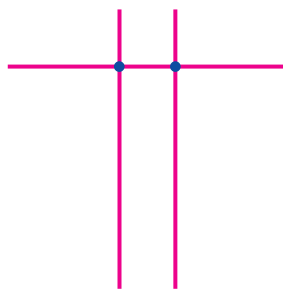

Fig. 8 (b)

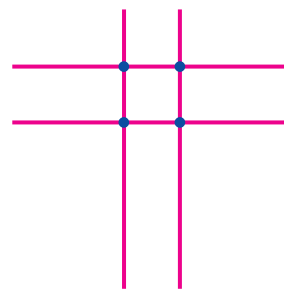

Fig. 8 (c)

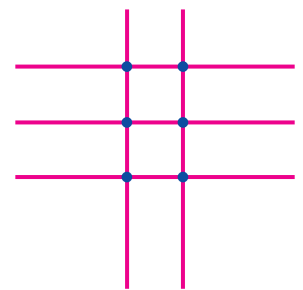

Fig. 8 (d)

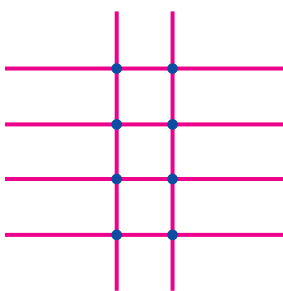

Fig. 8 (e)

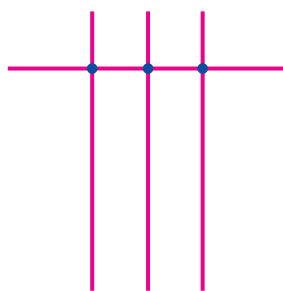

Fig. 8 (f)

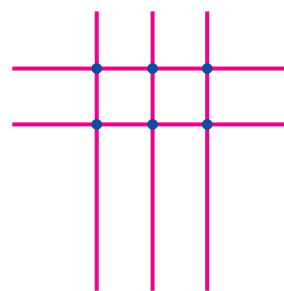

Fig. 8 (g)

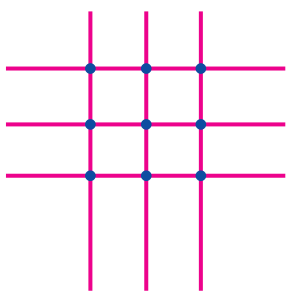

Fig. 8 (h)





**Observations :** Fill in the blanks :

- (i)  $2 \times 1 = \dots\dots\dots$  ,       $2 \times 2 = \dots\dots\dots$  ,       $2 \times 3 = \dots\dots\dots$   
 $2 \times 4 = \dots\dots\dots$  ,       $2 \times 5 = \dots\dots\dots$  ,       $2 \times 6 = \dots\dots\dots$   
 $2 \times 7 = \dots\dots\dots$  ,       $2 \times 8 = \dots\dots\dots$  ,       $2 \times 9 = \dots\dots\dots$
- (ii)  $3 \times 1 = \dots\dots\dots$  ,       $3 \times 5 = \dots\dots\dots$  ,       $3 \times 7 = \dots\dots\dots$   
 $3 \times 10 = \dots\dots\dots$

**Extension :** You may initiate discussion among the other students for the process of developing the tables of 4 and 5.

## ACTIVITY 9

*To identify a number as an even number or an odd number.*

**Learning objective** : To distinguish even and odd numbers.

**Pre-requisite** : Knowledge of numbers.

**Materials required** : Objects like beads/pebbles.

**Procedure** :

**Step 1.** Pick up a few beads and count them.

**Step 2.** Try to arrange them in pairs.

**Step 3.** Are you left with any unpaired bead? [Fig. 9(a)]

**Step 4.** Stick a few bindies on a page of your notebook as shown in Fig. 9(b)

**Step 5.** Count the number of bindies and record it.

**Step 6.** Draw boundaries around pairs of bindies as shown in Fig. 9(b), so that no bindi is paired twice.

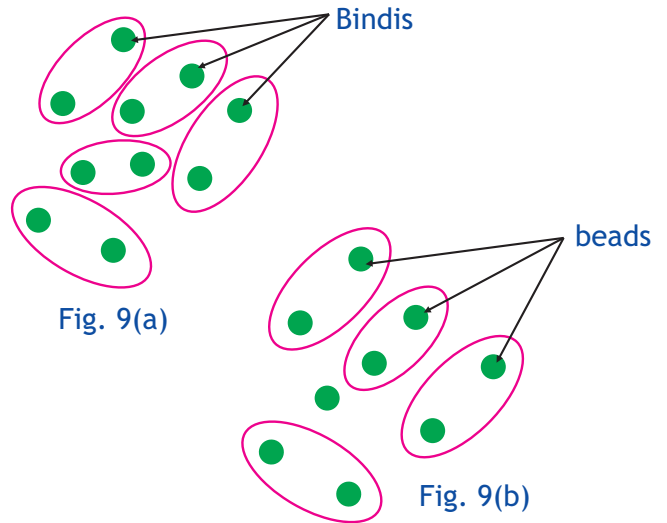

**Observations :**

1. How many beads did you count? .....
2. Was any bead left after pairing in Step 3. If yes, the number was .....
3. How many bindies did you stick? .....
4. Are you left with any unpaired bindi after pairing? Yes/No .....
5. Is the number of bindies even or odd? .....
6. Take a number (say) 36? Is it even or odd? .....

**Note :** If the total number of bindies can be paired then we say that the bindies are even in number. If any one of the bindies remain unpaired, then we say that the bindies are add in number.

**Extension :** What about the next number?

1. Take numbers 1 to 30 and classify them as even or odd numbers.
2. A given number of marbles may be distributed in two groups and then the concept of even / odd numbers can be strengthened.

## ACTIVITY 10

*To understand money transactions.*

**Learning objective :** To enhance the ability of handling money.

**Pre-requisite :** 1. Knowledge of numbers and their addition / subtraction.  
2. Knowledge of currency notes of different denominations in circulation.

**Materials Required :** Artificial currency notes of different denominations.

**Procedure :**

**Step 1.** Make/get some artificial notes of Re. 1, Rs. 2, Rs. 5, Rs. 10 and Rs. 20 denomination [see Fig. 10 (a)]

**Step 2.** Make combinations of notes to make Rs. 20 from this collection.

**Step 3.** Each student of the class performs Step 2 and records his /her observation in the following table

S.No.	Name	Re.1	Rs.2	Rs.5	Rs.10	Rs.20	Working
1.	Anju				2		$10+10=20$
2.	Neelam			2	1		$5+5+10=20$
3.	Priya		5		1		$2+2+2+2+10=20$

**Observations :**

1. Which combination has least number of notes? .....
2. Which combination has maximum number of notes? .....
3. Which other combination you can make? .....



**Extension :**

1. The students may be introduced to the notes of Rs. 50 and Rs.100.
2. The above activity may be extended using Rs.50/- and Rs.100/- notes for a toy costing Rs. 250/-.

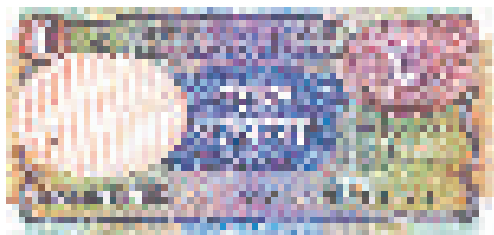
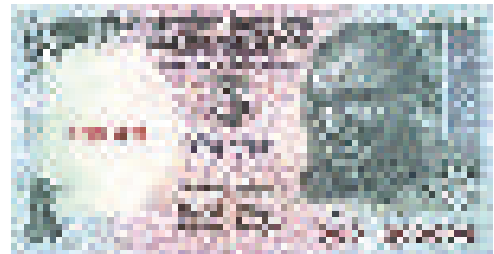
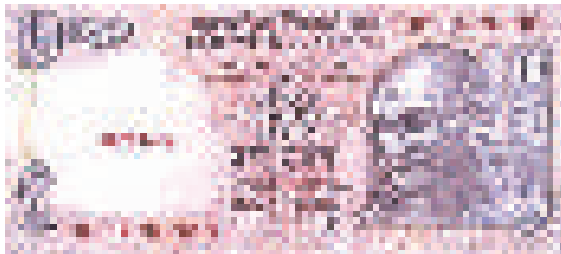

Fig. 10(a)



**Grade : 4**

Mathematics Laboratory in Primary  
& Upper Primary schools





## ACTIVITY 1

To draw the following shapes on a dot paper

- (a) Triangle
- (b) Rectangle
- (c) Square

**Learning Objective :** To understand of shapes of a triangle, a rectangle and a square.

**Pre-requisite :** Familiarity with the shapes such as triangle, rectangle and square.

**Materials required :** Dot papers, a pencil and a ruler.

**Procedure :** (a) Triangle

**Step 1.** Take any three dots A, B and C not in a line and join them to form a triangle. [Fig. 1(a)]. How many sides does it have? How many angles does it have?

**Step 2.** In Fig. 1(a) out of given dots join any three dots to form a triangle using a ruler.

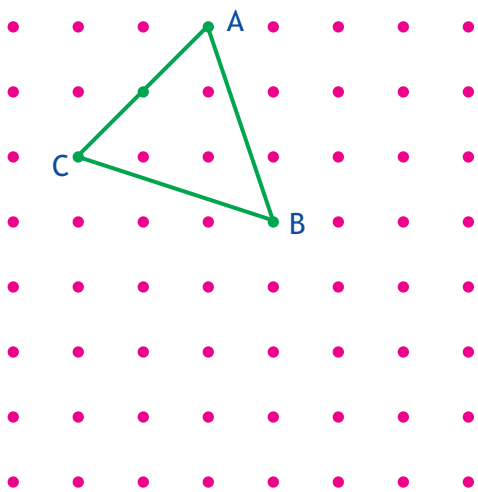

Fig. 1(a)

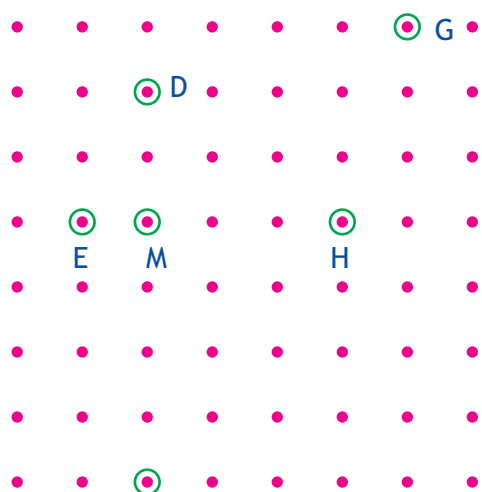

Fig. 1(b)

**Observations :** In Fig 1(b),

1. can you draw a triangle by joining the dots, D, M and F? ..... (Yes/No)
2. can you draw a triangle by joining the dots E, M and H? ..... (Yes/No)
3. can you draw a triangle by joining the dots D, E and H? ..... (Yes/No)

**Extension :** On a dot paper draw

1. two triangles joining five dots.
2. two triangles joining four dots.
3. three triangles joining seven dots.
4. three triangles joining six dots.

# 4

5. three triangles joining five dots.

### Procedure : (b) Rectangle

**Step 1.** Four dots M, N, O and P are joined to form a rectangle on the dot paper using a ruler Fig.1(c).

**Step 2.** Count and verify that the number of dots on the line joining M and N are four (excluding M and N)

**Step 3.** Similarly count dots on the remaining sides

Which sides of the given rectangle have equal number of dots on it?

**Step 4.** Observing and using above information make a rectangle by joining four points on a dot paper.

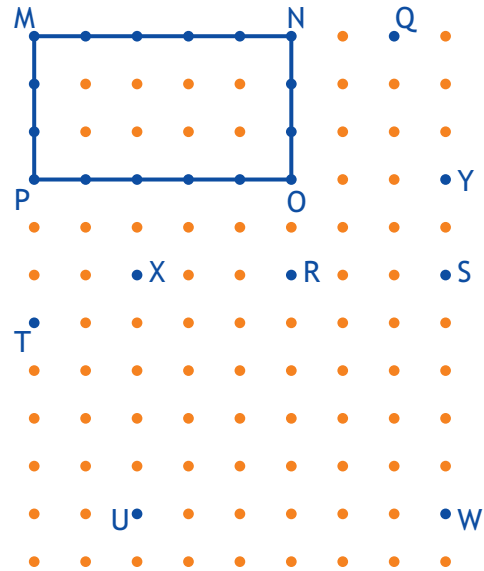

Fig. 1(c)

### Observations :

1. Can you make a rectangle by joining dots, S, R, O and Y, Fig. 1(c)? ..... (Yes/No)
2. Can you make a rectangle by joining dots T, R, W and U? ..... (Yes/No)
3. Can you make a rectangle by joining dots P, O, R and T? ..... (Yes/No)

### Extension : On a dot paper draw

1. two rectangles by joining six points
2. a rectangle in which one side covers seven dots and the other side three dots.

### Procedure : (e) Square

**Step 1.** Dots E, F, G and H are joined to form a square using a ruler. [Fig. 1(d)]

**Step 2.** Count the number of dots on each side. What do you observe?

**Step 3.** Observing and using above information make a square by joining four points on the given dot paper.

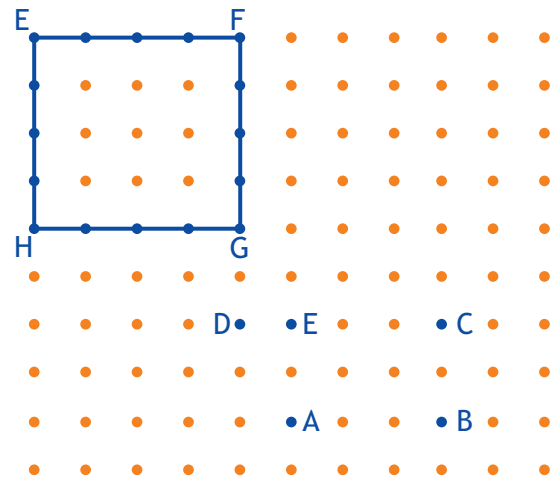

Fig 1(d)



**Observations :**

- (i) Can you make a square by joining dots A, B, C and D in Fig. 1(d)? ..... (Yes/No)
- (ii) Can you make a square by joining dots A, B, C and F in fig. 1(d)? ..... (Yes/No)
- (iii) What is the difference between a rectangle and a square?

**Extension :**

1. Make another square in the interior of the given square using a dot paper.
2. On a dot paper make two squares of the same size.

# 4

## ACTIVITY 2

- (a) To find the centre and radius of a circle by paper folding.
- (b) To make a geometrical design using a pair of compasses and a ruler.
- (c) To make a pattern of circles with
- (i) the same centre but different radii
  - (ii) the same radius but different centres on the same line

**Learning objective** : To familiarise with circle and its parts.

**Pre-requisite** : Knowledge of paper folding, handling a ruler and compasses.

**Materials required** : Sheets of paper, a ruler, a pencil, a pair of scissors, a pair of compasses, any circular object like a bangle or a bowl.

**Procedure** : (a) To find the centre and radius of a circle by paper folding

**Step 1.** Put bangle on the paper and move a pencil around it to get a circle [Fig. 2(a)].

**Step 2.** Cut out the circle with the help of a pair of scissors [Fig. 2(b)].

**Step 3.** Fold it into two halves and make a crease. [Fig. 2(c)]

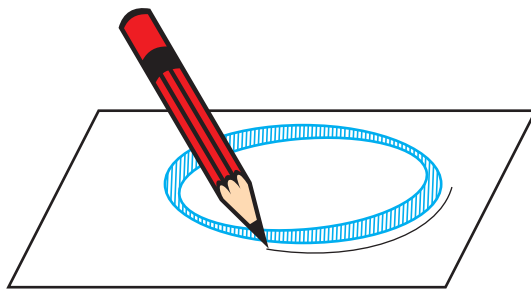

Fig 2(a)

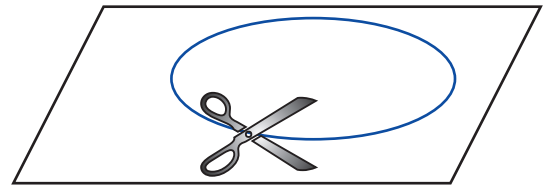

Fig 2(b)

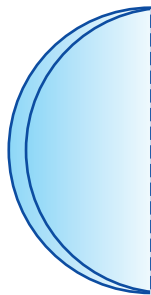

Fig 2(c)

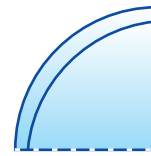

Fig 2(d)

**Step 4.** Fold it again and make another crease as shown. [Fig. 2(d)]

**Step 5.** Unfold to get two creases intersecting at a point. [Fig. 2(e)]

This point is the centre of the circle.

**Step 6.** Name the centre of the circle as O and the end points of the creases as A, B, C and D [Fig. 2(f)].

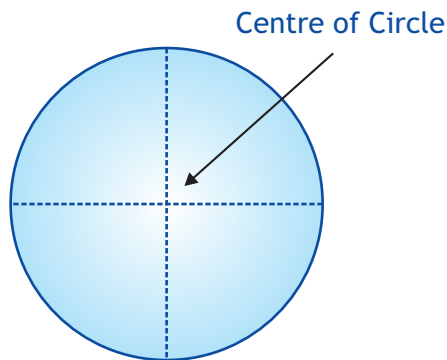

Fig 2(e)

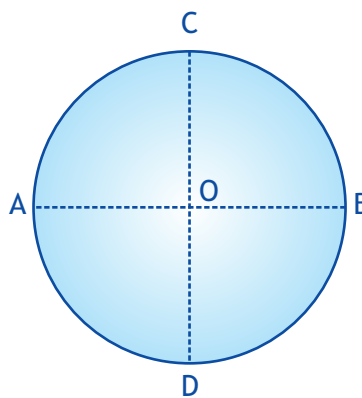

Fig 2(f)

Then OA, OB, OC and OD are radii of the circle.

**Step 7.** Measure radii OA, OB, OC and OD

**Observations:**

(i) Length of OA = ....., OB = ....., OC = ....., OD = .....,

(ii) Are the above lengths equal? ..... Yes/No

**Procedure : (b) and (c)**

**Step 1.** Draw a circle of any radius using a pair of compasses and a pencil. [Fig. 2(h)]

**Step 2.** Taking any point on the circle as centre, draw a part of the circle of the same radius intersecting the circle at A and B as shown in figure [Fig. 2(i)].

**Step 3.** Taking A and B as centres, draw parts of circle and complete the design as in Fig. 2(j). Can you now develop another design as in Fig. 2(k)?

**Step 4.** Taking any point on the paper as centre draw circles of different radii. [Fig. 2(l)]

**Step 5.** Draw a line on the paper and taking a point on it as centre draw a circle of any radius. Keeping the radius same and by taking suitable points on the line as centres, draw circles to get the pattern as in figure. [Fig. 2(m)]

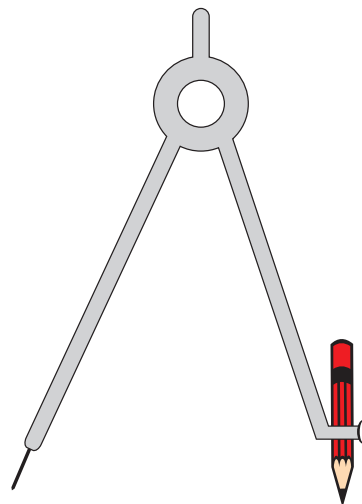

Fig 2(g)

# 4

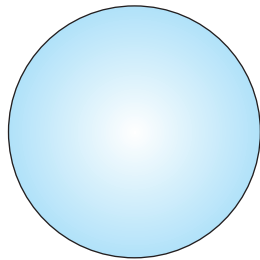

Fig 2(h)

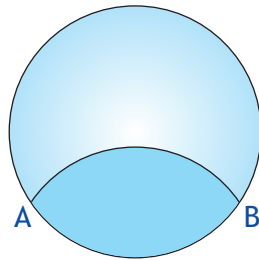

Fig 2(i)

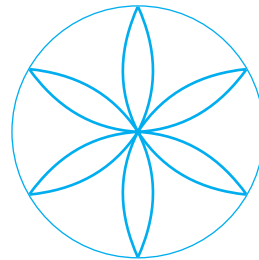

Fig 2(j)

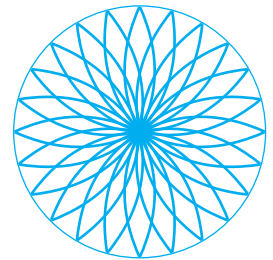

Fig 2(k)

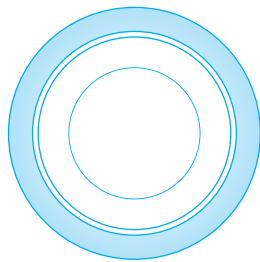

Fig 2(l)

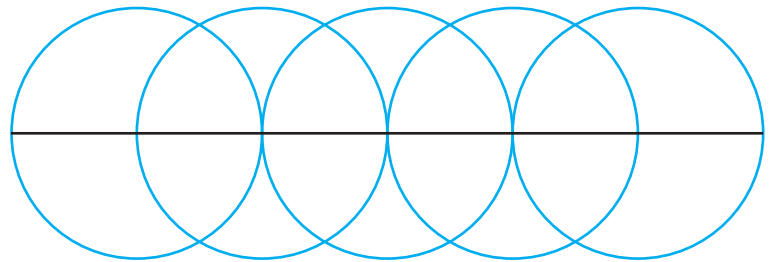

Fig 2(m)

**Observations :**

- (i) How many circles can be drawn from the same centre but different radii? .....
- (ii) How many circles can be drawn of the same radius but different centres on the same line? .....

**ACTIVITY 3**

a. To divide a square by paper folding, to make :

(i) four equal rectangles

(ii) four equal squares

(iii) four equal triangles

b. To divide a rectangle, by paper folding, to make :

(i) four equal rectangles

(ii) four equal triangles

**Learning objective** : To visualize rectangles, squares and triangles of same size.

**Pre-requisite** : Familiarity with the shapes of rectangle, square and triangle.

**Materials required** : Paper cutouts in the shape of a square and a rectangle.

**Procedure** : For (a) (i)

**Step 1.** Take a cut out in the shape of square Fig.3(a)

**Step 2.** Fold it in the middle so that the two parts completely overlap each other. Fig.3(b). Can you identify the shapes obtained after folding?

**Step 3.** Further fold the paper along its longer side so that both portions overlap each other Fig.3(c).

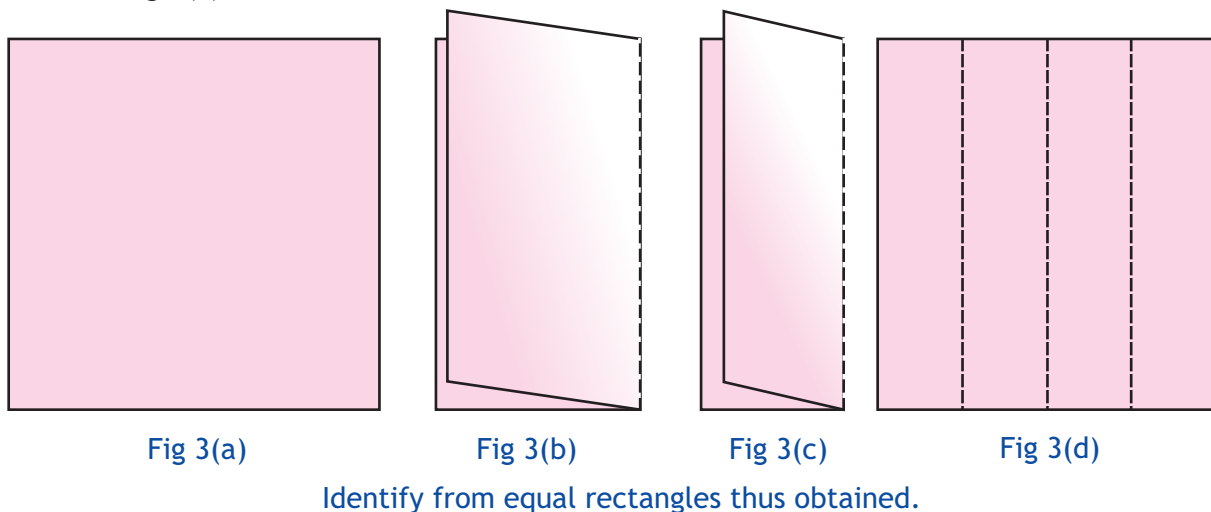

**Step 4.** Now unfold it. Fig. 3(d).

**For (a) (ii)**

**Step 1.** Take a square cutout again and fold it as in Step 2 above. [Fig. 3(b)]

**Step 2.** Now fold it again in the middle along its shorter side. [Fig. 3(e)]

**Step 3.** Unfold it. Fig.3(f). Identify four equal squares thus obtained.

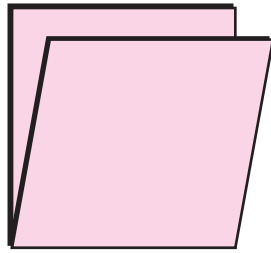

Fig 3(e)

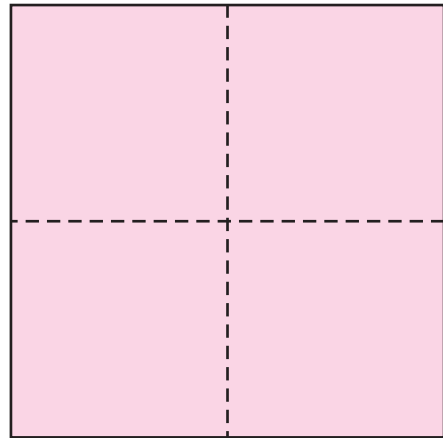

Fig 3(f)

For (a) (iii)

**Step 1.** Take a square shaped cut out [Fig3(a)].

**Step 2.** Fold it so that its two opposite corners overlap each other [Fig.3(g)]. Identify the shape obtained after folding.

**Step 3.** Again fold it in the middle along the longer side so that the two parts overlap each other [Fig.3(h)].

**Step 4.** Unfold and identify four equal triangles. [Fig.3(i)].

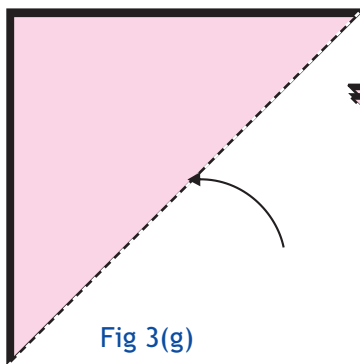

Fig 3(g)

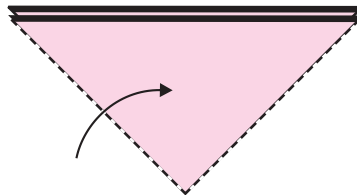

Fig 3(h)

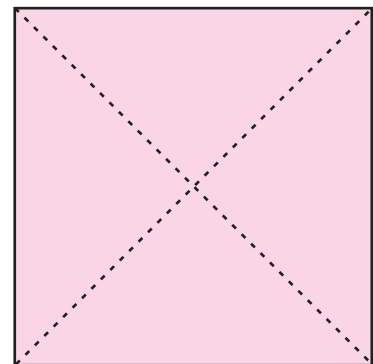

Fig 3(i)

**Observations :**

**Complete the following table:**

Activity	Number of parts of unfolded cut out	Are all the parts equal?	Shape of each part obtained by folding
(a)(i)			
(a)(ii)			
(a)(iii)			

**For activity 3(b), take a rectangle and proceed in the same way as in Activity 3(a).**

## ACTIVITY 4

(a) To shade  $\frac{1}{4}$  th part of your palm impression.

(b) To fill a given region with thumb impressions.

**Learning objective :** To visualize

(a)  $\frac{1}{4}$  as a part of whole, (b) interior of a region.

**Pre-requisite :** Knowledge of fractions.

**Materials required :** Water colours, a ruler, a square paper, a pencil and plain paper.

**Procedure :** For (a)

**Step 1.** Place your palm on a squared paper and draw its outline [Fig. 4(a)].

**Step 2.** Draw a rectangle surrounding your palm impression [Fig. 4(b)].

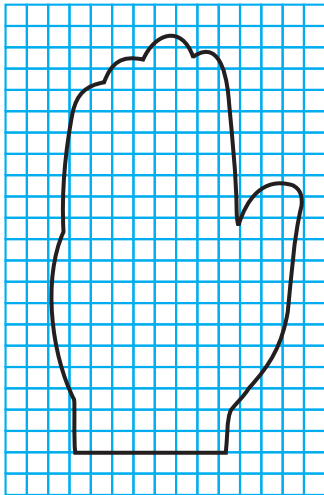

Fig 4(a)

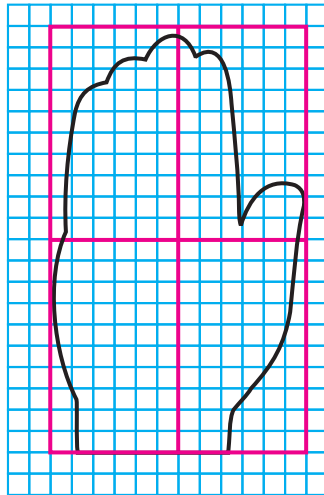

Fig 4(b)

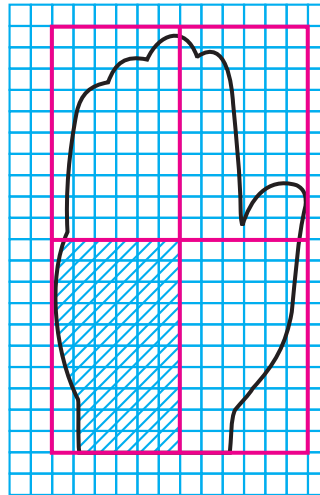

Fig 4(c)

**Step 3.** Divide this rectangle into four equal parts and colour its one part (only the interior region of palm)[Fig. 4(c)].

**For (b)**

**Step 1.** Draw a triangle on a plain sheet [Fig. 4(d)].

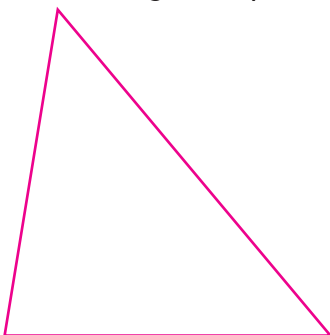

Fig 4(d)

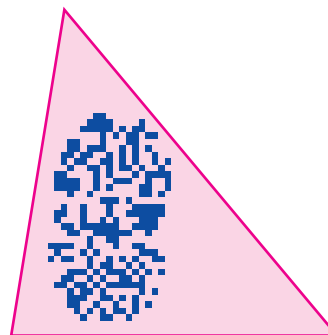

Fig 4(e)

# 4

**Step 2.** Mix water and colour in a bowl.

**Step 3.** Dip your thumb into it and fill inside the triangle [Fig. 5(e)].

**Observation :**

- (i) Number of parts in Fig. 4(b) = .....
- (ii) Number of parts shaded in Fig. 4(c). = .....
- (iii) Fraction representing the shaded part in Fig. 4(c) is = .....
- (iv) Fraction representing the unshaded part Fig. 4(c) is = ..... (appx.)
- (v) Number of thumb impressions required to fill the triangle is = .....



## ACTIVITY 5

*To make a tiling pattern on a dot paper using geometrical shapes as tiles.*

**Learning objective :** To generate patterns using geometrical shapes.

**Pre-requisite :** Knowledge of geometrical shapes, use of dot paper.

**Materials required :** Square dotted paper, pencil/pen

**Procedure :**

**Step 1.** Observe the given geometrical patterns in Fig. 5(a)(i) and 5(a)(ii)

**Step 2.** Extend the given tiling patterns using shaded geometrical shape as a tile.

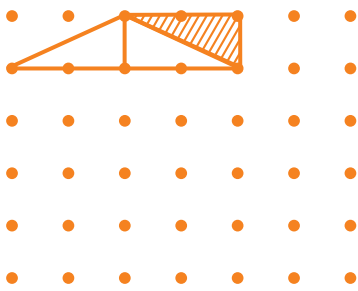

Fig. 5(a) (i)

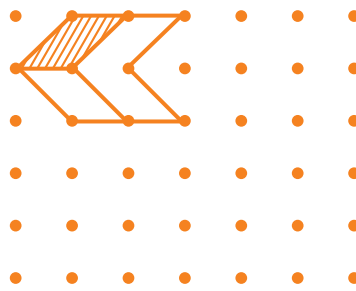

Fig. 5(a) (ii)

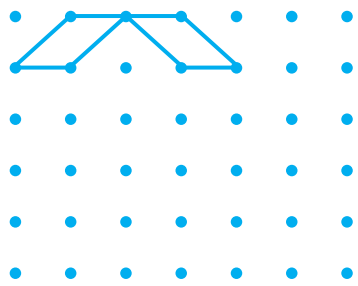

Fig. 5(b) (i)

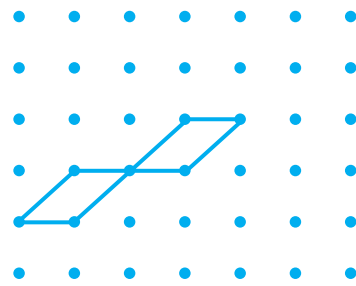

Fig. 5(b) (ii)

**Observations :**

1. In Fig. 5(a)(i), how many line segments have been used to make a single tile?

.....

2. In Fig. 5(a)(ii), how many lines have been used to make a single tile?

.....

3. The second tiling shape i.e. Fig. 5(a)(ii) can be arranged in different patterns as in Fig. 5(b)(i) and Fig. 5(b)(ii). Which of these patterns of tiles can be used to fill the given space completely and which cannot?

.....

# 4

## ACTIVITY 6

*To write a secret code message where all the English alphabets are replaced by numbers 1 to 26, respectively, in order.*

**Learning objective :** To understand coding and decoding of message.

**Pre-Requisite :** Knowledge of numbers upto 100, playing with numbers by forming different patterns/sequences, say, even, odd, back counting forward counting.

**Materials required :** Paper sheet and a pencil

**Procedure :**

**Step 1.** Write all the alphabets in order.

**Step 2.** Assign each alphabet a number.

These numbers may follow a pattern.

e.g. A-1, B-2, C-3, D-4 and so on.

**Step 3.** Take any word and for each alphabet write the corresponding assigned number.

e.g. for the word FRIEND

F - 6

R - 18

I - 9

E - 5

N - 14

D - 4

So, the secret code for the word FRIEND becomes 6 (18) 9 5 (14) 4

**Observation :** Rohit and his friend developed a secret code and wrote:

Cab as 624

Bag as 42 (14)

Meeta and her friend developed another code and wrote

Cab as 312

Bag as 217

Can you write the numbers assigned to the letter 'g' by Rohit and by Meeta?

**Extension :** Take different words and write their codes. Give your friend a message in this coded form.

## ACTIVITY 7

- (a) To measure the length of the boundary line of the top of a book using thread and a scale.
- (b) To measure the length of the boundary line of any shape drawn on a paper using thread and a scale.

**Learning Objective :** To understand the concept of perimeter of plane figures.

**Materials required :** A book, a thread, a measuring tape / centimeter scale and pens with red ink and blue ink.

**Pre-requisite :** Use of a centimeter scale for measurements..

**Procedure :** **For (a)** Measuring boundary line of the top of a book.

- Step 1.** Take a book
- Step 2.** Consider its top. Place a thread at one side on the top of the book
- Step 3.** Mark a point near one end of a string with red ink. Let this point be A.
- Step 4.** Place this point of the string at one of the corner of the top of the book and stretch it around the top reaching to the same point. Put a mark again on the string with blue ink.
- Step 5.** Take a centimeter scale/measuring tape. Measure the distance between the two marks. While measuring keep the thread stretched.
- Step 6.** Record the measurement as length of boundary of the book.

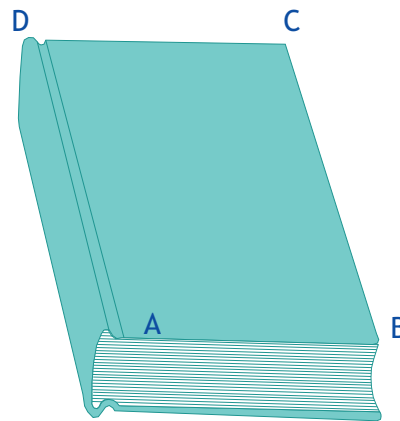

Fig. 7(a)

**For (b)** Measuring boundary of a given figure.

- Step 1.** Draw a closed figure on a plane paper.
- Step 2.** Mark any point A on the figure and place one end of a thread at A and mark this end with blue ink. [Fig. 7(b)]
- Step 3.** Stretch the thread along the boundary line of figure to meet again at A mark this point on the thread with ink.
- Step 4.** Measure the distance between two marks on the thread using centimeter scale.

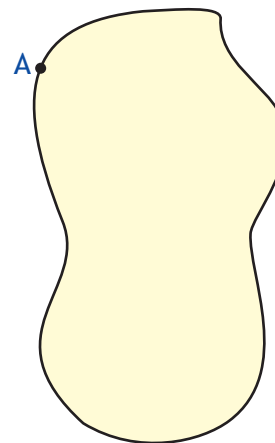

Fig. 7(b)

**Observations :**

- (i) The length of the boundary of the top of the book is .....
- (ii) The length of the boundary line of the figure in Fig. 7(b) is .....

**Extension :** Measure the boundary of different plane figures from your surroundings and record them.

# 4

## ACTIVITY 8

*To arrange cutouts of a tangram set in the shape of the first alphabet of your name.*

**Learning objective :** To make different shapes using given geometrical shapes.

**Pre-requisite :** Familiarity with tangram cut outs and their use.

**Materials required :** Tangram sets, a pencil/pen and paper sheets.

**Procedure :**

**Step 1.** Take cut outs of a tangram set.

**Step 2.** Arrange its different pieces to write the first alphabet of your name. For help see Fig.8(a)

**Observations :**

- (i) Number of pieces of tangram used in one letter is .....
- (ii) Number of pieces of tangram used in your name is .....

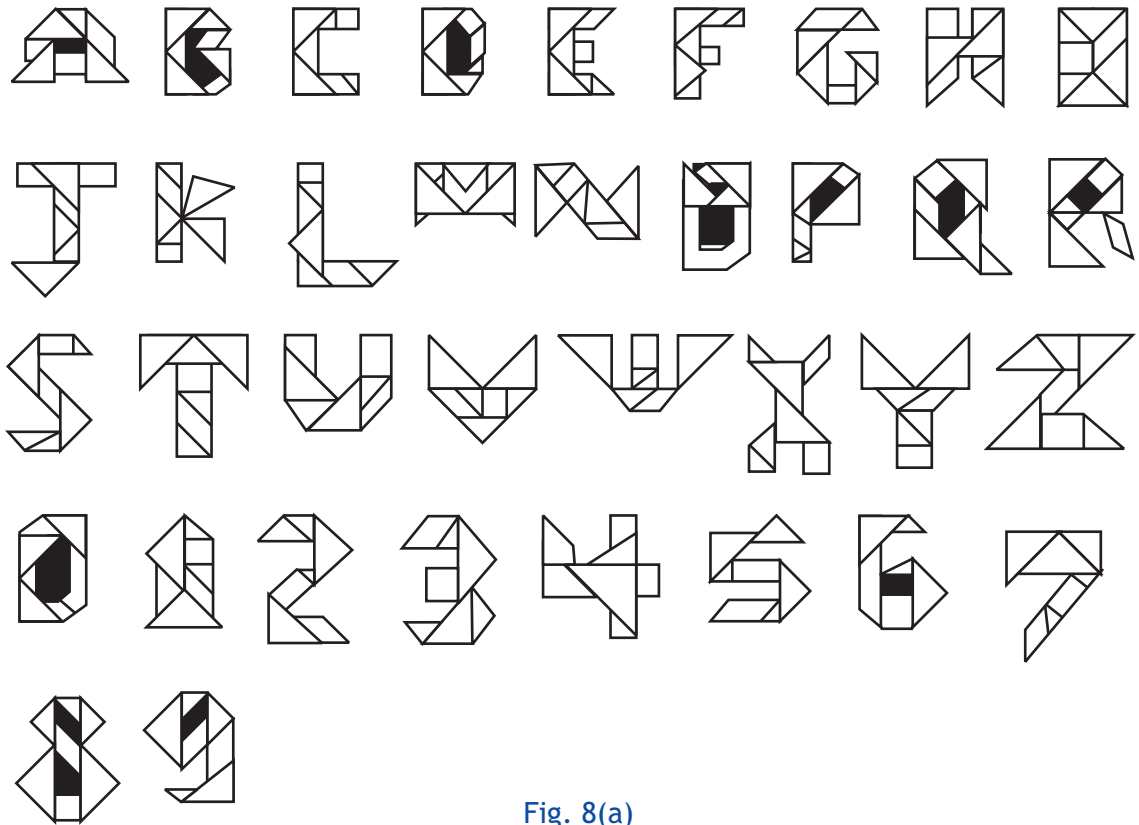

Fig. 8(a)

## ACTIVITY 9

*To measure the heights and weights of all members in a group.*

**Learning Objective :** To collect and interpret the data.

**Pre-requisites :** Knowledge of using measuring tape and weighing machine.

**Material required :** A measuring tape, a weighing machine, a pen/pencil, paper sheets.

**Procedure :**

**Step 1.** Divide the class in small groups say of 5 members each.

**Step 2.** In each group one member should measure the heights and weights of other members.

**Step 3.** Record the heights and weights of all the members of a group in the following table:



Fig. 9(a)

Name	Height (cms)	Weight (kgs)

**Observations :**

1. Compare your observation with other groups.

	Group A	Group B	Group C	Group D
Tallest member	Height	Height	Height	Height
Shortest member	Height	Height	Height	Height
Maximum weight	Weight	Weight	Weight	Weight
Minimum weight	Weight	Weight	Weight	Weight

Name the tallest member in the class? \_\_\_\_\_

Name the shortest member in the class? \_\_\_\_\_

Name the member having maximum weight in the class? \_\_\_\_\_

# 4

Name the member having minimum weight in the class? \_\_\_\_\_

What is the height of the tallest member? \_\_\_\_\_

What is the height of the shortest member? \_\_\_\_\_

## Extension :

1. Collect the data of the different sports liked by children, favourite colours, favourite food items, favourite hobbies and record the data of the entire class and find:
  - (a) Which item (say a particular sport) is liked by maximum children
  - (b) Which item is least liked
2. Collect the data of the time taken by different students of a class, in 100m race and prepare a table to find
  - (a) the student who took the least time
  - (b) the student who look the maximum time



**Grade : 5**

Mathematics Laboratory in Primary  
& Upper Primary schools





## ACTIVITY 1

*To make a set of Tangram cutouts by paper folding and cutting and to make geometric figures using its pieces.*

**Learning objective :** To familiarise with geometrical figures.

**Pre-requisite :** The knowledge of basic geometrical shapes : triangle, square, rectangle.

**Materials required :** An 8x8 grid, a pair of scissors, a pen/pencil and a ruler.

**Procedure :** 1(a) To make a Tangram set.

**Step 1.** Take a 8x8 grid and label it as ABCD, which is a square. [Fig. 1(a)]

**Step 2.** Fold the square ABCD along BD such that point 'C' falls on point 'A' and mark the crease BD.

**Step 3.** Unfold the grid and cut along the crease.

**Step 4.** Take any one cutout obtained in Step 3 say ABD and fold it through the vertex A so that the two end points of the longest side meet exactly and mark the crease.

**Step 5.** Unfold and cut along the crease and label the two parts as 1 & 2 [Fig. 1(b)].

**Step 6.** Take the other cutout obtained in Step 3 and fold it in such a way that point containing a right angle exactly falls on the mid point of its longest side.

**Step 7.** Unfold and cut along the crease formed. Label the triangle cutouts as 3 [Fig. 1(c)].

**Step 8.** Take the remaining cutout obtained in Step 6 and fold along the lines drawn. [Fig.1(d).]

**Step 9.** Unfold and cut along the creases. Label the cutouts as 4, 5, 6 & 7. [Fig. 1(e).]

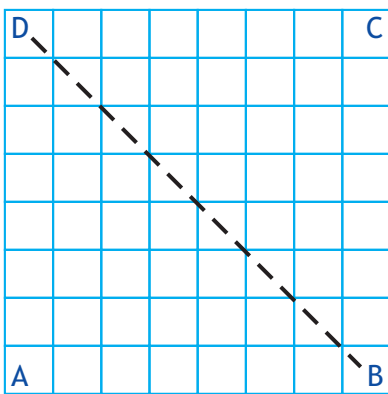

Fig. 1(a)

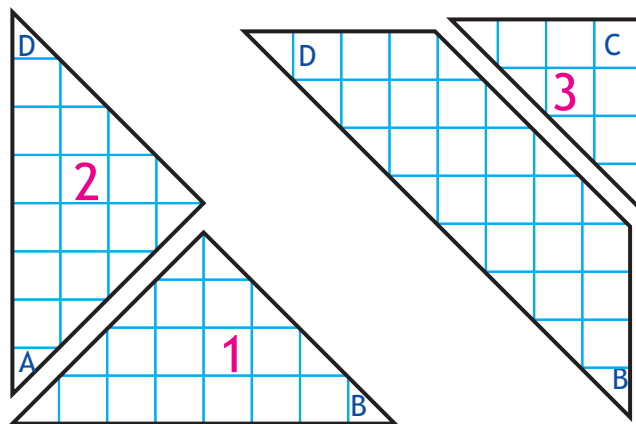

Fig. 1(b)

Fig. 1(c)

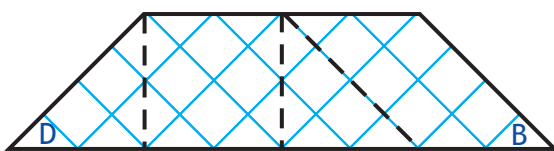

Fig. 1(d)

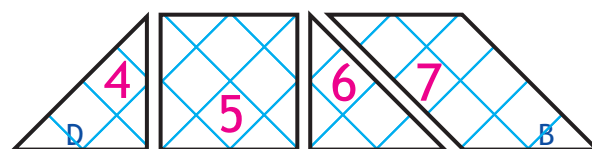

Fig. 1(e)



The seven shapes obtained represent a set of tangram pieces.

**Observations :**

- (i) Can you make a triangle using any 2 cutouts of a tangram? If yes, then write their numbers .....
- (ii) Can you make a square using any 2 cutouts of a tangram? If yes, then write their numbers .....
- (iii) Can you make a rectangle using any 2 cutouts of a tangram? If yes, then write their numbers .....
- (iv) Can you make a triangle using any 3 cutouts of a tangram? If yes, then write their numbers .....
- (v) Can you make a square using any 3 cutouts of a tangram? If yes, then write their numbers .....
- (vi) Can you make a rectangle using any 3 cutouts of a tangram? If yes, then write their numbers .....

**Extension :**

- (i) Make a triangle, a square and a rectangle using only 2 pieces of the tangram cutouts.
- (ii) Make a triangle, a square and a rectangle using only 3 pieces of the tangram cutouts.

## ACTIVITY 2

*To find the area of each part of a set of Tangram pieces by counting number of complete squares and half squares.*

**Learning objective :** To understand the method of finding the area of different geometrical shapes.

**Pre-requisite :** Knowledge of tangram pieces and area.

**Materials required :** An 8x8 grid, a pair of scissors, glue, a pen/pencil and paper sheet.

**Procedure :**

**Step 1.** Take an 8x8 grid. Find its area (A) by counting the number of unit squares.

**Step 2.** Draw a tangram on a 8x8 grid.

**Step 3.** Count the number of complete and half unit squares in each shape.

**Step 4.** Find the area of each shape by adding number of complete squares to half the number of half squares.

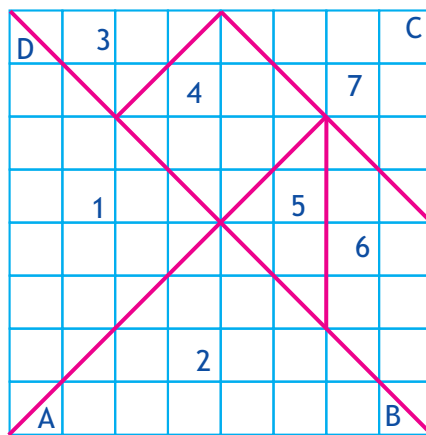

Fig. 2(f)

**Observations:**

Cut out number	Number of complete squares	Number of half squares	Area (a)	Fraction (a/A)
1				
2				
3				
4				
5				
6				
7				

(i) Do all shapes have equal area? Explore the relationship between the area of each shape to the original square.

(ii) What fraction is the area of each shape to the original square.



### ACTIVITY 3

*To make closed shapes using match sticks.*

**Learning objective** : To understand closed and open figures.

**Pre-requisite** : Knowledge of closed figures.

**Materials required** : Match-sticks or any other sticks of the same size.

**Procedure** :

- Step 1.** Take two match sticks. Place them in different ways or positions, as shown in Fig. 3a. Can you get a closed shape? .....
- Step 2.** Take three match sticks. Place them in different positions. Can you get a closed shape? If yes, which shape is obtained? .....
- Step 3.** Observe different shapes obtained. Do you always get a closed shape? .....
- Step 4.** Repeat the activity by taking 4 match sticks, 5 match sticks and 6 match sticks. Observe in each case which of them is closed and which is open.

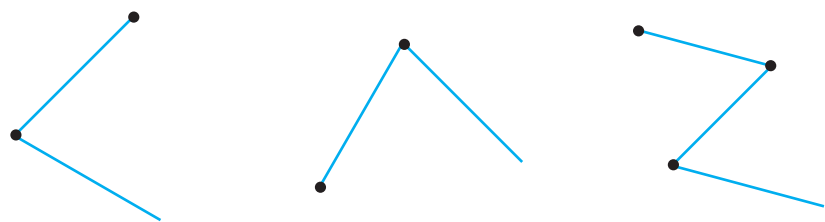

Fig. 3(a)

**Observation :**

- (i) How many, minimum number of match sticks are needed to get a closed shape? .....
- (ii) How many minimum number of sticks are required to make a rectangle? .....
- (iii) How many minimum number of sticks are required to make a square? .....

## ACTIVITY 4 A

*To identify a right angle, an angle less than a right angle and an angle more than a right angle using body postures and to draw them using stick drawings.*

**Learning objective :** To familiarize and differentiate between angles viz. a right angle, an angle more than a right angle and an angle less than a right angle.

**Pre-requisite :** Knowledge of a right angle.

**Materials required :** A ruler and coloured pens

**Procedure :**

**Step 1.** Fold your one arm (see picture) Do you observe any angle?

**Step 2.** Make body postures as shown in the picture making angles between body parts.

**Observation :**

- Identify the right angles .....
- Identify the angles less than a right angle .....
- Identify the angles more than a right angle .....

**Extension :** The activity may be extended to observing angles in different Yoga Asana postures.

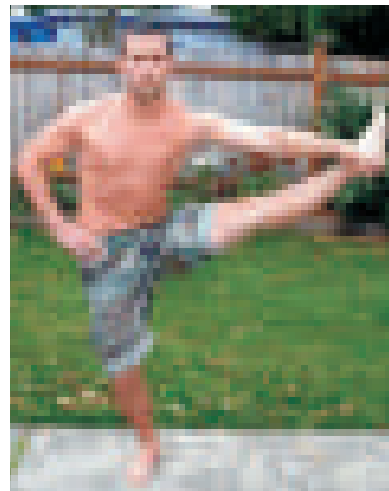



## ACTIVITY 4 B

*Write the word MATHEMATICS using line segments and observe the number of right angles, number of angles more than a right angle and number of angles less than a right angle.*

**Learning objective :** To differentiate between a right angle, an angle less than a right angle and an angle more than a right angle.

**Pre requisite :** Knowledge of a right angle.

**Materials required :** A paper, a ruler and coloured pens.

**Procedure :**

**Step 1.** Write the word MATHEMATICS on a paper using a ruler.

**Step 2.** Observe the angles in different alphabets.

**Step 3.** Mark right angles, angles more than a right angle and angles less than a right angle with different colours.

**Observations :**

Fill your observations in the table given below :

Letter	number of right angles	Number of angles less than a right angle	Number of angles more than a right angle
M			
A			
T			
H			
E			
I			
C			
S			

**Extension :** You may take some other word and do the same activity.

## ACTIVITY 5 A

*To make the face of a clock by paper folding.*

**Learning objective :** To develop the skill of dividing a circle into 12 equal parts.

**Pre-requisite :** Knowledge of the face of a clock.

**Materials required :** A circular cutout, a ruler and coloured pen, two needles of unequal size.

**Procedure :**

- Step 1.** Take a circular cutout and fold it in two equal halves. [Fig. 5a(1)]
- Step 2.** Fold yet again to divide the shape obtained in step 1 in two equal halves. [Fig. 5a(2)]
- Step 3.** Make 2 folds in the shape obtained in step 2 such that it get divided into 3 equal halves. [Fig. 5a(3)]
- Step 4.** Unfold and draw lines on creases. Mark numbers 1 to 12 as on face of clock. [Fig. 5a(4)]
- Step 5.** Fix two needle as shown in Fig 5a (5).

(i) What is the time shown in Fig. 5a (5)? .....

**Observation :**

1. Mark the position of hours needle at 3 and minutes needle at 1 and read the time .....
2. Mark the position of hours needle at 5 and minutes needle at 9 and read the time .....

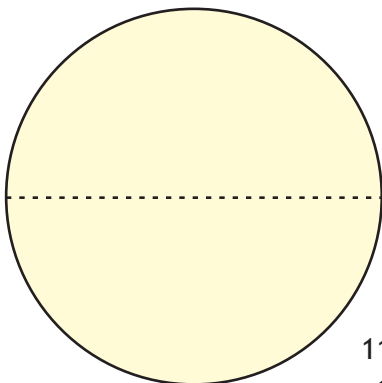

Fig. 5a (1)

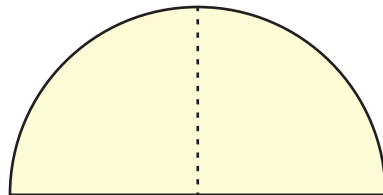

Fig. 5a (2)

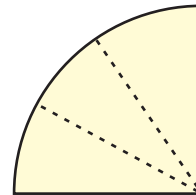

Fig. 5a (3)

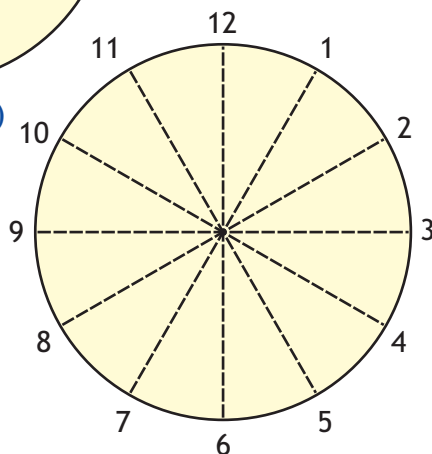

Fig. 5a (4)

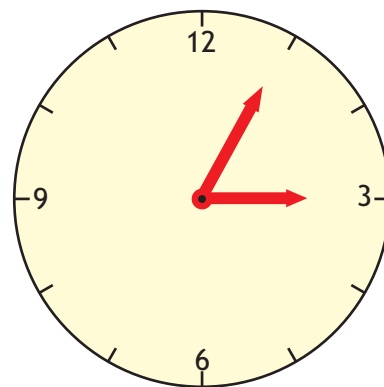

Fig. 5a (5)

# 5

## ACTIVITY 5 B

*To observe hands of a clock at different times in a day and record types of angles formed in each case between the two hands.*

**Learning objective :** To recognize angles equal to a right angle, less than a right angle and greater than a right angle formed by the hands of a clock at different times.

**Pre-requisite :** Reading a clock.

**Materials required :** A working clock.

**Procedure:**

**Step 1.** Take a clock.

**Step 2.** Set the clock at 9:10, 9:30, 9:45 and 10:00

**Step 3.** observe the smaller angle turned between the two hands.

**Observation :**

**Complete the following table with your observations:**

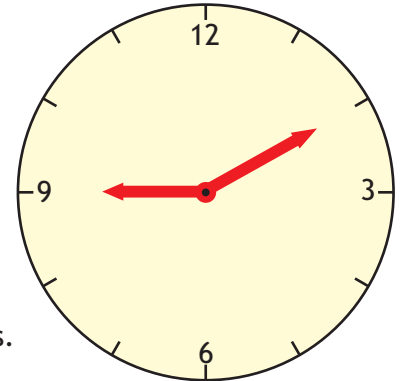

Fig. 5b (1)

Time	Angle between the hands		
	A right angle	less than a right angle	greater than a right angle
9o'clock			
9.10			
9.30			
9.45			
10.00			

**Extension :** You may set the clock at different times and find when the angle between the two hands is :

- (a) A right angle
- (b) Greater than a right angle
- (c) Less than a right angle



## ACTIVITY 6

*To make rectangles of different dimensions on a squared paper using 12 adjacent squares and calculate the perimeter and area of each of the rectangles so formed.*

**Learning objective :** To understand that shapes having the same area may have different perimeters.

**Pre-requisite :** Knowledge of perimeter and area.

**Materials required :** A squared paper, a pen and sketch pens.

**Procedure :**

**Step 1.** Take a squared paper of dimension 12x8. Shade or colour twelve unit squares taking all in one row. [Fig. 6(a)]

What shape do you get?

**Step 2.** Make more rectangles of different dimensions by taking 12 such unit squares.

**Step 3.** Find the area and perimeter of each rectangle, so formed.

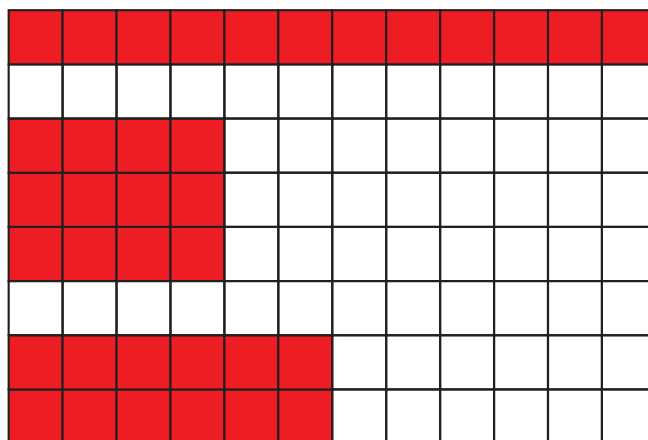

Fig.6(a)

**Step 4.** Record your observations in a table.

**Observation :** Find the perimeter and area of each shape and record them in a table.

Rectangle size	Perimeter	Area
1 x12	.....	.....
2x6	.....	.....
3x4	.....	.....

Is there any difference in the perimeter of the three rectangles? ..... (Yes/No)

Is there any difference in the area of the three rectangles? ..... (Yes/No)

**Extension :** You may form different rectangles taking different number of squares and study the change in perimeter, while the area remains the same.



### ACTIVITY 7

To calculate the perimeter of different shapes formed by shading six adjacent squares of dimensions 1 cm each on a squared paper.

**Learning Objective :** To verify that shapes having same area may have different perimeter.

**Pre-requisite :** Knowledge of perimeter and area of squares and rectangles.

**Materials Required :** A squared paper and colours.

**Procedure :**

**Step 1.** Take a squared paper and form different shapes using 6 unit squares as shown in Fig. 7(a)

**Step 2.** Find the perimeter and area of each shape and record them in a table.

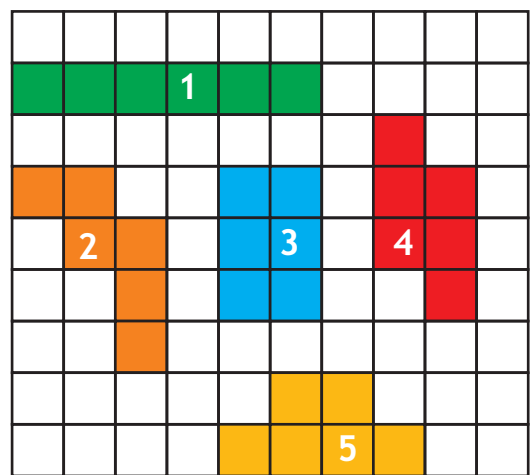

Fig. 7(a)

**Observations :**

Figure No.	Area	Perimeter
1		
2		
3		
4		
5		

- (i) Does the area remain same in each shape? ..... (Yes/No)
- (ii) Does the perimeter remain same in each shape? ..... (Yes/No)
- (iii) What do you conclude? .....

**Extension:** You may take 8 or 10 squares, get different shapes placing them adjacent to each other in any order and find the change in perimeter while the area remains the same.

## ACTIVITY 8

(a) To represent the fractions  $\frac{1}{2}, \frac{1}{3}, \frac{1}{4}, \frac{1}{5}$  etc. by paper folding using rectangular strips of paper.

(b) To represent the fractions  $\frac{1}{2}, \frac{1}{4}, \frac{3}{4}$ , etc. of a circular region by paper folding.

**Learning Objective :** To understand fraction as a part of whole.

**Pre-requisite :** Knowledge of fractions.  $\frac{1}{2}, \frac{1}{3}, \frac{3}{4}, \frac{3}{5}$  etc.

**Materials Required :** A few paper strips of uniform width and circular cutouts of paper of same size.

**Procedure :** 8(a)

**Step 1.** Take a paper strip (say 10 cm long approx). Fold it in the middle so that the two parts overlap each other. Unfold and colour one part. Each part represents half of  $\frac{1}{2}$  of the whole strip. [Fig. 8(a)]



Fig. 8(a)

**Step 2.** Take another strip and fold it as in Step 1 and again fold it in the middle so that the two parts of the folded strip are exactly equal. Open the folds again.

Shade or colour one part. [Fig. 8(b)]



Fig. 8(b)

**Step 3.** Take a strip and fold it in three equal parts, unfold it.

**Step 4.** Shade/Colour one part [Fig. 8(c)]



Fig. 8(c)

**Step 5.** Similarly take one more strip and fold it into 5 equal parts and shade one of the parts.

**Observation :**

- (i) Shaded/coloured part in Fig. 8(a) represents the fraction .....
- (ii) Shaded/coloured part in Fig 8(b) represents the fraction .....
- (iii) Shaded/coloured part in Fig 8(c) represents the fraction .....
- (iv) Shaded/coloured part in the figure obtained in Step 5 represents the fraction .....



**Extension :**

- (a) Try to represent the fractions  $\frac{1}{8}$  and  $\frac{1}{10}$ .
- (b) Shade the parts to represent  $\frac{2}{3}$ ,  $\frac{2}{5}$  and  $\frac{2}{8}$ .

**Procedure : 8(b)**

**Step 1.** Take a circular cutout of a paper. Fold it in the middle so that the two parts exactly overlap each other. Unfold and mark the crease. Shade or colour one part Fig. 8(d).

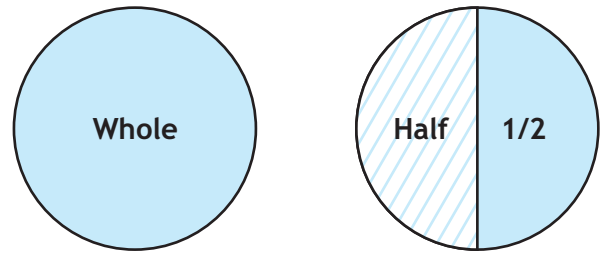

Fig. 8(d)

**Step 2.** Take another circular cutout. Fold it as in Step 1 and again fold it to get four equal parts. Shade or colour one part

**Observation :**

- (i) Shaded/coloured part in Fig. 8(d) represents the fraction .....
- (ii) unshaded/uncoloured part in Fig. 8(d) represents the fraction .....
- (iii) Shaded/coloured part in the figure obtained in the Step 2 represents the fraction .....
- (iv) Unshaded/uncoloured part in the figure obtained in Step 2 represents the fraction .....

**Extension :** Try to represent th fraction  $\frac{1}{3}$ ,  $\frac{2}{3}$ ,  $\frac{1}{5}$ .

**ACTIVITY 9**

To find the lines of symmetry in the following shapes by paper folding.

(i) Square

(ii) Rectangle.

**Learning Objective :** To understand the idea of line symmetry and lines of symmetry.

**Pre-requisite :** Knowledge of lines of symmetry.

**Materials Required :** Coloured papers, a ruler and colored pens.

**Procedure :**

**Step 1.** Cut a square of any dimension from a squared paper. Label it as ABCD. [Fig 9(a)]

**Step 2.** Fold the square cutout in such a way that BC falls on AD exactly.

**Step 3.** Unfold the paper and draw a line on the crease. [Fig. 9(b)]. This is one line of symmetry of the square ABCD. [Fig. 9(b)]

**Step 4.** Again fold the square cutout in such a way that AB falls on DC exactly.

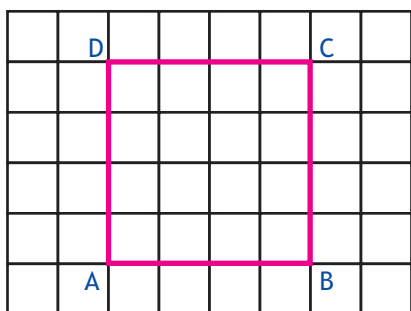

Fig. 9(a)

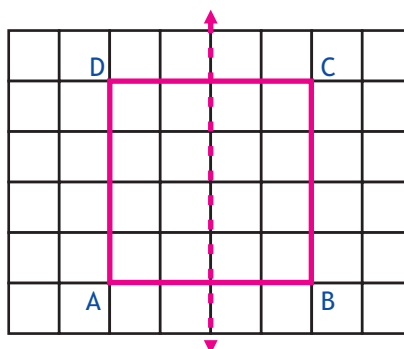

Fig. 9(b)

**Step 5.** Unfold the paper and draw a line on the crease. [ Fig. 9(c)]

This is also another line of symmetry of the square ABCD.

**Step 6.** Fold the square cutout along the diagonal AC.

**Step 7.** Unfold the paper and draw a line on the crease. [ Fig. 9(d)]

This is also a line of symmetry of square ABCD

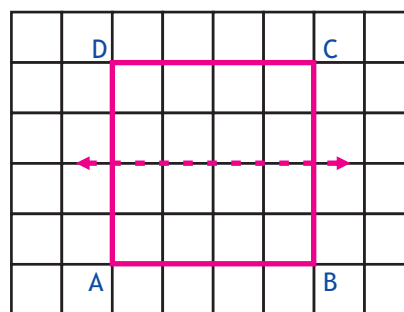

Fig. 9(c)

**Step 8.** Fold the square cutout along the diagonal BD.

**Step 9.** Unfold the paper and draw a line on the crease. [ Fig. 9(e)].

This is also one line of symmetry of square ABCD.

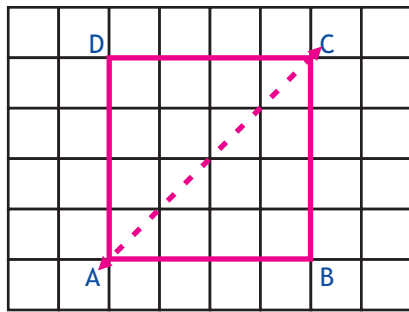

Fig. 9(d)

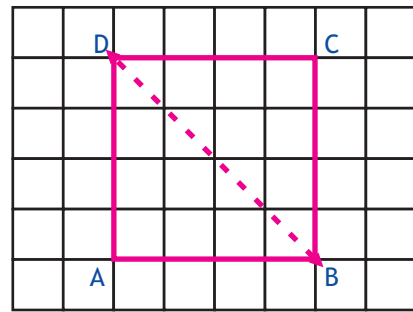

Fig. 9(e)

**Step10.** Repeat the activity using a rectangular cutout and find out the lines of symmetry?

**Observation :**

1. How many lines of symmetry can be drawn in a square? .....
2. How many lines of symmetry can be drawn in a rectangle? .....

## ACTIVITY 10

To make  $3 \times 3$  magic square using numbers 1 to 9.

**Learning Objective :** To make a magic square.

**Pre-requisite :** Knowledge of addition of numbers in rows, columns and diagonals.

**Materials Required :** A grid paper, a ruler, a pencil and a colored pen.

**Procedure :**

**Step 1.** On a grid paper draw a  $3 \times 3$  square ABCD. [Fig. 10(a)]

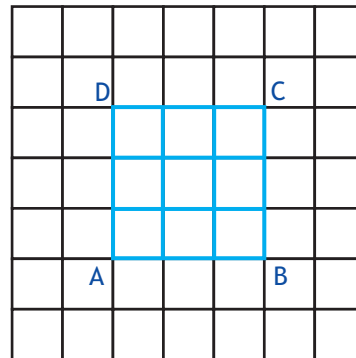

Fig. 10(a)

**Step 2.** Extend the middle row and middle column. [Fig. 10(b)]

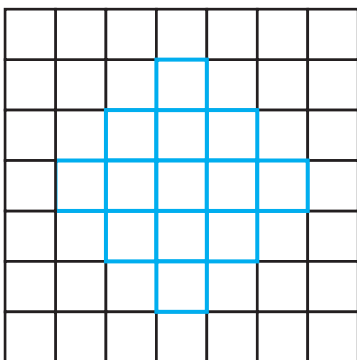

Fig. 10(b)

**Step 3.** Write numbers from 1 to 9 diagonally in boxes. [Fig. 10(c)]

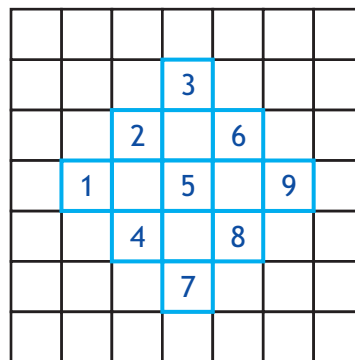

Fig. 10(c)

**Step 4.** Shift numbers written outside the original ( $3 \times 3$ ) square to the empty boxes as indicated by arrows. [Fig. 10(d)]

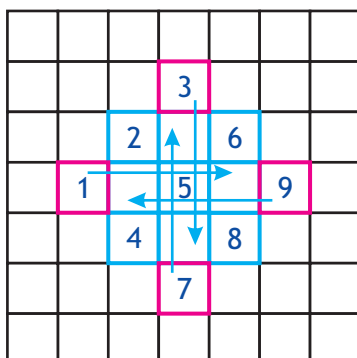

Fig. 10(d)

**Step 5.** Add the numbers row wise.

Observe the sum of each row.

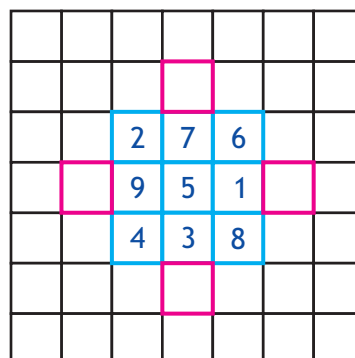

Fig. 10(e)





**Step 6.** Add the numbers column wise.

Observe the sum of each column.

**Step 7.** Add the numbers diagonally.

Observe the sum of each diagonal.

**Observation :**

Location	Numbers	Sum of Numbers
First Row		
Second Row		
Third Row		
First Column		
Second Column		
Third Column		
One Diagonal		
Another Diagonal		

**Extension :** The activity may be extended for making a 3x3 magic square for any 9 consecutive numbers. You may try to make magic square of order 5x5 for 25 consecutive numbers.



## ACTIVITY 11

To make cubes and cuboids of various dimensions using unit cubes

- (i) A cuboid of dimensions 2 units  $\times$  3 units  $\times$  2 units
- (ii) A cuboid of dimensions 3 units  $\times$  3 units  $\times$  2 units
- (iii) A cube of side 3 units

**Learning Objective :** To understand the concept of dimensions in solid shapes.

**Pre-requisite :** Knowledge of a cube and a cuboid.

**Materials Required :** Unit cubes.

**Procedure : (i)**

**Step 1.** Take 2 unit cubes and place them adjacent to each other as shown in Fig. 11(a).

**Step 2.** Add 4 unit cubes to the previous shape as shown in Fig. 11(b).

**Step 3.** Add 6 unit cubes on the top of previous layer of cubes as shown in Fig. 11(c).

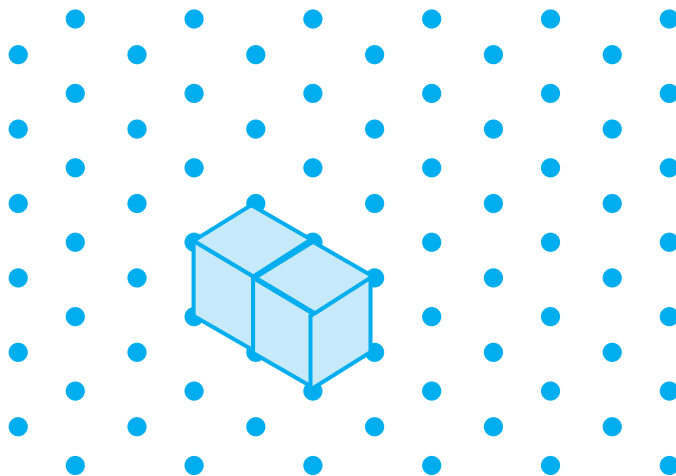

Fig. 11 (a)



**Step 4** Make cuboids and cubes of other dimensions as in (i), (ii) and (iii) and note observations after every step.

**Observations :**

Dimensions of shape obtained

After Step 1 = .....

After Step 2 = .....

After Step 3 = .....

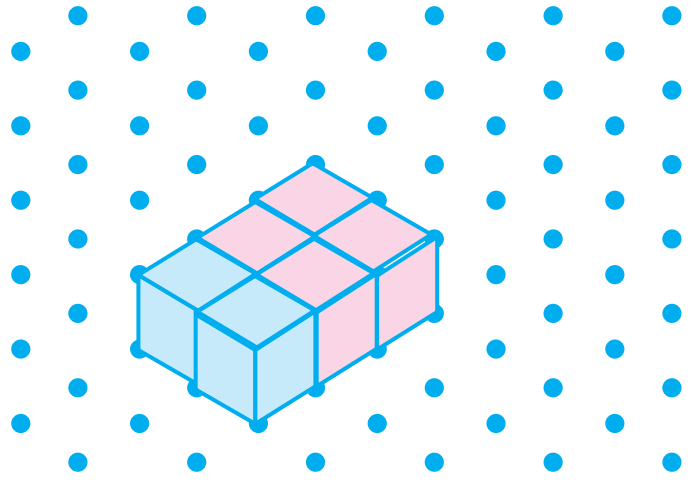

Fig. 11 (b)

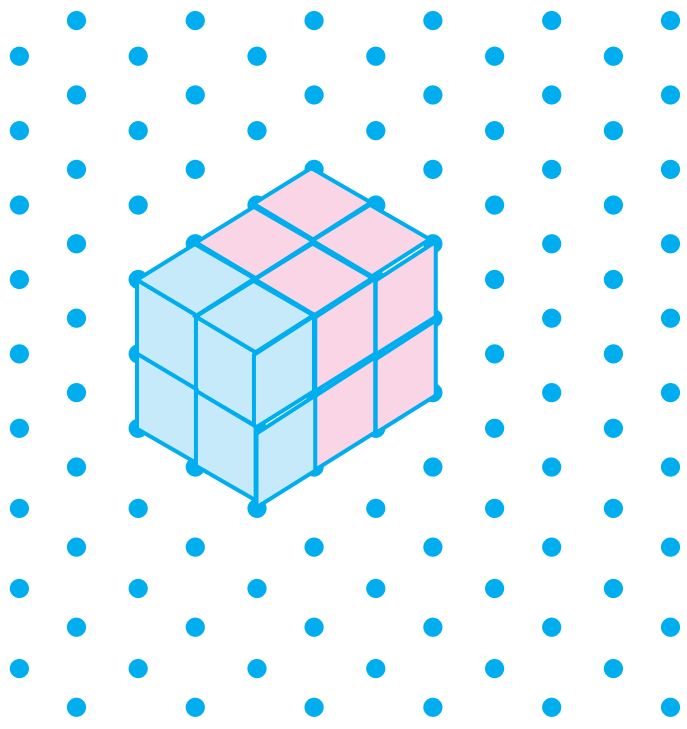

Fig. 11 (c)



**Grade : 6**

Mathematics Laboratory in Primary  
& Upper Primary schools





**ACTIVITY 1**

- (a) To verify that addition is commutative for whole numbers, by paper cutting and pasting.
- (b) To verify that multiplication is commutative for whole numbers, by paper cutting and pasting

**Learning Objective :** To understand that addition as well as multiplication are commutative for whole numbers.

**Pre requisite :** (i) Knowledge of addition and multiplication of whole numbers.  
(ii) Knowledge of commutative property of whole numbers.

**Materials required :** Grid papers, a pair of scissors and glue

**Procedure (a) :** (a) To verify  $3 + 4 = 4 + 3$

**Step 1.** Cut out two strips each of length 3 units from a grid paper and shade them with any colour (say Red) Fig. 1(a).

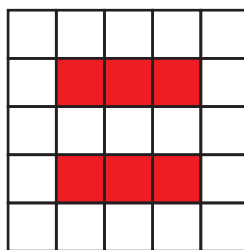

Fig 1(a)

**Step 2.** Cut two strips each of length 4 units from a grid paper and shade them with different colour (say Blue ) Fig. 1(b).

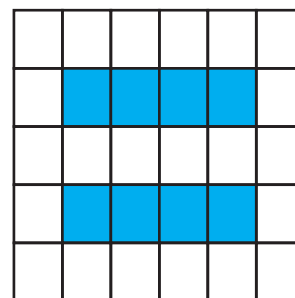

Fig 1(a)

**Step 3.** For representing  $3 + 4$ , paste one strip of length 3 units and then paste another strip of length 4 units in the same line on the grid paper without leaving any gap Fig. 1(c).

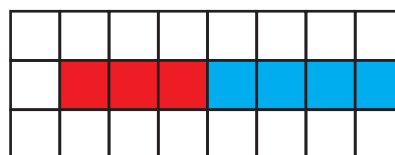

Fig 1(c)

**Step 4.** For representing  $4 + 3$ , paste one strip of length 4 units and then paste another strip of length 3 units in the same on the same grid paper line without leaving any gap Fig. 1(d).

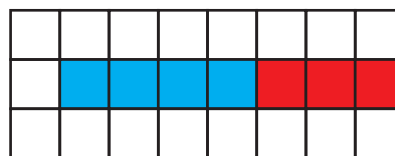

Fig 1(d)

**Step 5.** Now, compare (by counting number of boxes) the length of strips obtained in Step 3 and Step 4.

Are they equal?

**Step 6.** Repeat the activity for some more pairs of whole numbers and write your result.

**Observations:**

Number of shaded boxes in the presentation of  $3 + 4 = \dots\dots\dots$

Number of shaded boxes in the presentation of  $4 + 3 = \dots\dots\dots$



Thus,  $3 + 4 = 4 + 3$

Hence addition is commutative for whole numbers.

**Procedure (b):** To verify  $3 \times 4 = 4 \times 3$

**Step 1** Cutout three strips each of 4 boxes from a grid paper and shade them with any colour (Say blue).

**Step 2** Place them on a grid paper to form a rectangle as shown in Fig. 1(d)

**Step 3** Now cutout 4 strips each of length 3 units from the grid paper. Colour them (say Red) and place them on the same grid paper to form a rectangle as shown in Fig. 1(e)

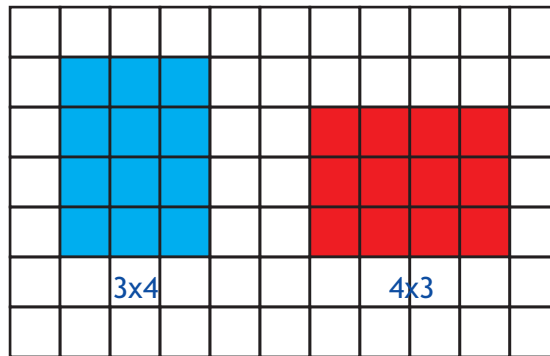

Fig 1(e)

**Step 4** Now compare the number of boxes in each of the two rectangles obtained. Are they equal?

**Step 5** Repeat the activity for some more pairs of whole numbers and write your result.

**Observations:** Number of shaded unit squares in the representation of  $3 \times 4 = \dots\dots\dots$

Number of shaded boxes in the representation of  $4 \times 3 = \dots\dots\dots$

Thus ,  $3 \times 4 = 4 \times 3$

Hence, multiplication is commutative for whole numbers.

## ACTIVITY 2

To find prime numbers between 1 to 100 by Eratosthenes Sieve's method.

**Learning Objective :** To list prime numbers between 1 to 100.

**Pre-requisite :** Knowledge of factors and multiples.

**Materials Required :** A grid paper / squared paper, sketch pens.

**Procedure :**

- Step 1.** Take a grid paper/squared paper and cutout a 10 x 10 square from it.
- Step 2.** Write numbers from 1 to 100 in this grid as shown in Fig. 2(a).
- Step 3.** Colour the box with number 1 with any colour say blue as shown in Fig 2(a).
- Step 4.** Now encircle the number 2 with green colour, as it is a prime number.
- Step 5.** Next, cross all the multiples of 2 with red colour as shown in Fig. 2(b).
- Step 6.** Next, encircle the number 3 (prime number) with green colour and cross all multiples of 3 by red colour as shown in Fig. 2(c)

1	2	3	4	5	6	7	8	9	10
11	12	13	14	15	16	17	18	19	20
21	22	23	24	25	26	27	28	29	30
31	32	33	34	35	36	37	38	39	40
41	42	43	44	45	46	47	48	49	50
51	52	53	54	55	56	57	58	59	60
61	62	63	64	65	66	67	68	69	70
71	72	73	74	75	76	77	78	79	80
81	82	83	84	85	86	87	88	89	90
91	92	93	94	95	96	97	98	99	100

Fig. 2(a)

1	②	3	X	5	X	7	X	9	X
11	X	13	X	15	X	17	X	19	X
21	X	23	X	25	X	27	X	29	X
31	X	33	X	35	X	37	X	39	X
41	X	43	X	45	X	47	X	49	X
51	X	53	X	55	X	57	X	59	X
61	X	63	X	65	X	67	X	69	X
71	X	73	X	75	X	77	X	79	X
81	X	83	X	85	X	87	X	89	X
91	X	93	X	95	X	97	X	99	X

Fig. 2(b)

- Step 7.** Encircle the next prime number 5 with green colour and cross all it's multiples by red colour.
- Step 8.** Encircle the next prime number 7 with green colour and cross all it's multiples by red colour.
- Step 9.** Continue with this process till all the numbers are either encircled (prime numbers) or crossed to obtain Eratosthenes sieve.





1	②	③	X	5	X	7	X	X	X
X	X	13	X	X	X	17	X	19	X
X	X	23	X	25	X	X	X	29	X
31	X	X	X	35	X	37	X	X	X
41	X	43	X	X	X	47	X	49	X
X	X	53	X	55	X	X	X	59	X
61	X	X	X	65	X	67	X	X	X
71	X	73	X	X	X	77	X	79	X
X	X	83	X	85	X	X	X	89	X
91	X	X	X	95	X	97	X	X	X

Fig. 2(c)

1	②	③	X	⑤	X	⑦	X	X	X
⑪	X	⑬	X	X	X	⑰	X	⑲	X
X	X	⑳	X	X	X	X	X	㉑	X
㉓	X	X	X	X	X	㉗	X	X	X
㉙	X	㉛	X	X	X	㉟	X	X	X
X	X	㉝	X	X	X	X	X	㉟	X
㊱	X	X	X	X	X	㊳	X	X	X
㊵	X	㊷	X	X	X	X	X	㊹	X
X	X	㊻	X	X	X	X	X	㊽	X
X	X	X	X	X	X	㊿	X	X	X

Fig. 2(d)

- (i) Encircled numbers are .....
- (ii) Crossed numbers are .....
- (iii) 1 is neither a prime nor a ..... number
- (iv) Smallest prime number is .....
- (v) Total number of prime numbers between 1 and 100 = .....



## ACTIVITY 3

(a) To make a cube using the given net and count the number of faces, vertices and edges.

(b) To check which of the given nets can be folded to form a cube.

**Learning Objective :** To understand the formation of a cube and to identify its faces, vertices and edges,

**Pre-requisite :** Knowledge of vertices, edges and faces of a solid object, knowledge of a cube and its nets.

**Materials required :** A set of given nets. Tracing paper, carbon papers, a thick paper, a pair of scissors and glue.

**Procedure : (a)**

**Step 1.** Trace the given net Fig. 3(a) on a tracing paper.

**Step 2.** Now copy this drawing on a thick paper using a carbon paper as shown in Fig. 3(b)

**Step 3.** Cutout this net using a pair of scissors.

**Step 4.** Fold it along the dotted lines.

**Step 5.** Apply glue on its flaps to form a cube. Fig 3(c)

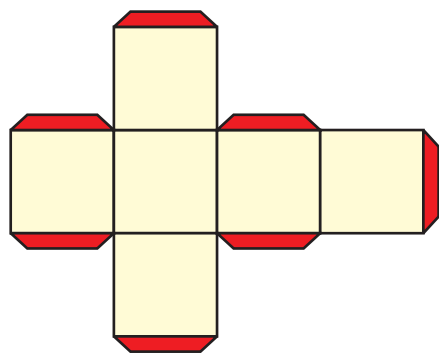

Fig 3(a)

Thick  
Paper

Carbon  
Paper

Tracing  
Paper

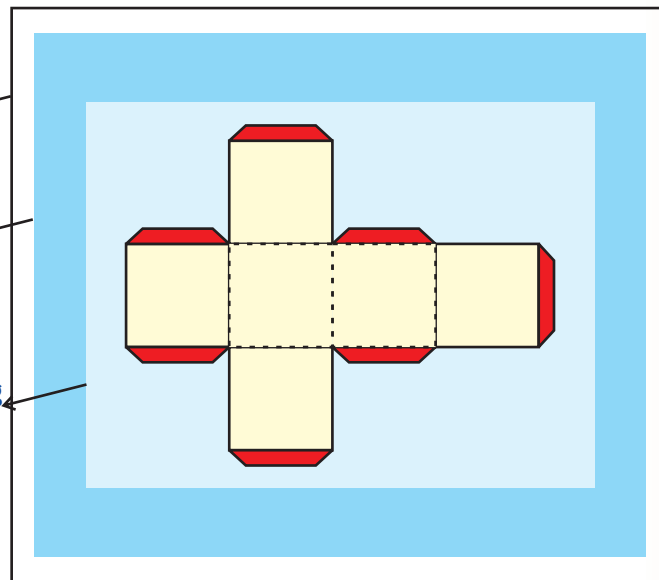

Fig 3(b)

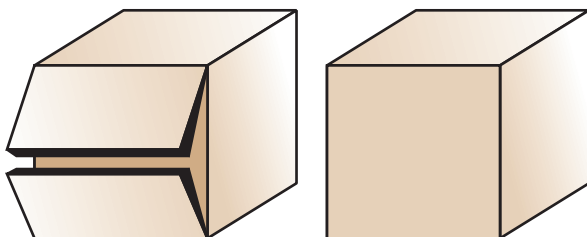

Fig 3(c)

# G

## Observations :

1. Number of faces = .....
2. Shape of each face is .....
3. Number of vertices = .....
4. Number of edges = .....
5. Length of each side of cube = .....

## Procedure : (b)

Take one net out of the given nets Fig.3(d) and try to form a cube by following the above Steps 1 to 5. colour the nets which form a cube. Repeat the activity by taking other nets.

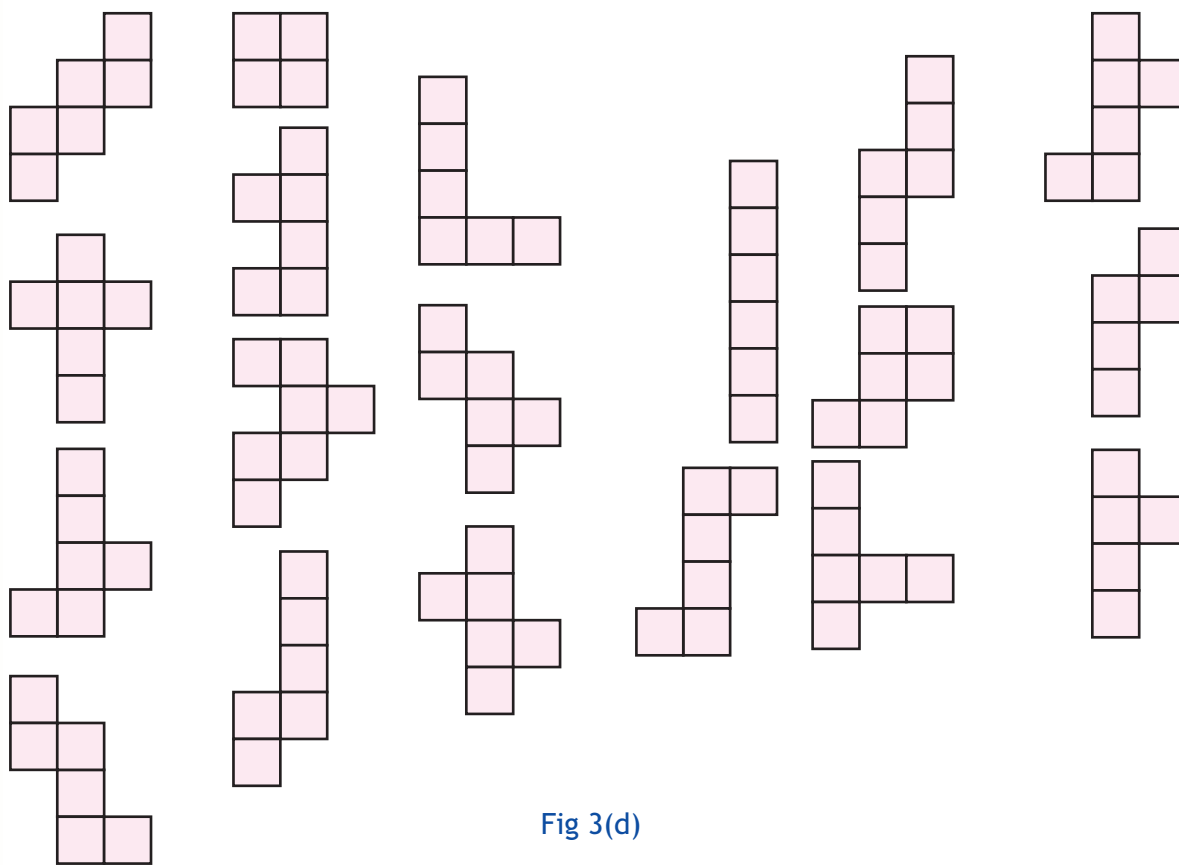

Fig 3(d)

## Observations:

1. Which of the given nets can be folded to get a cube? .....

## ACTIVITY 4

*To find the HCF of two given numbers, by paper cutting and pasting.*

**Learning Objective :** To understand the concept of HCF of two numbers.

**Pre-requisite :** Comparison of two numbers, knowledge of

Division algorithm : Dividend = Divisor x Quotient + Remainder

**Materials Required :** Coloured grid papers (2 different colours say green and red), a pair of scissors, glue, a ruler, and a pencil.

**Procedure :**

**Step 1.** Take any two numbers say 24 and 16.



Fig. 4(a)

**Step 2.** Cut out a strip of length 24 units using green colour grid paper as shown in Fig.4(a).



Fig. 4(b)

**Step 3.** Cut out another strip of length 16 units using red colour grid paper as shown in Fig. 4(b).

**Step 4.** Place the red strip along the green strip as shown in the Fig. 4(c) and cut out the remaining part of the green strip.

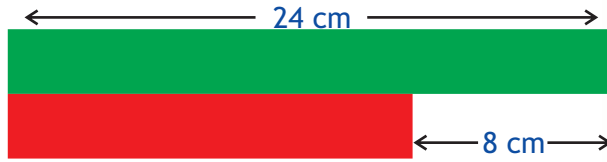

Fig. 4(c)

**Step 5.** Observe that the remaining part of green strip cut out is of length 8 units and is smaller than the red colour strip i.e. the strip of length 16 units.

**Step 6.** Now place the smaller cut out strip (green) along the larger cut out strip (red) and cut out the extra part (red strip) as shown in Fig. 4(d).

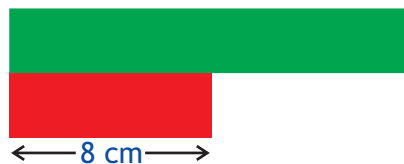

Fig. 4(d)

**Step 7.** Repeat the activity till both strips are equal.

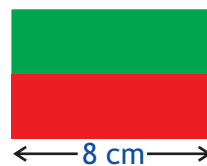

Fig. 4(d)

**Observations :**

- (i) In Step 4, the length of the green strip = ..... units
  - (ii) In Step 6, the length of the red strip = ..... units
  - (iii) Is there any part of any strip left when green strip of length 8 units was placed on the red strip?..... Yes/No
- HCF of 24 and 16 = .....

**Extension :** (i) Find the HCF of (i) 40 and 16, (ii) 12, 15 and 6.

# 6

## ACTIVITY 5

*To classify the triangles on the basis of sides and angles from the given set of triangles.*

**Learning Objective :** To understand different types of triangles.

**Pre-requisites :** Knowledge of sides and angles of a triangle. Skill of measuring line segment using a ruler and skill of measuring angles using a protractor.

**Materials required :** A ruler, protractor and coloured pencils and a set of triangles of different types.

**Procedure :** On the basis of Angles.

**Step 1.** In the given set of triangles, measure all the angles of each triangle using a protector. [Fig. 5(a)]

**Step 2.** Mark all acute angles with yellow colour, all right angles with red colour and all obtuse angles with green colour.

**Step 3.** Complete the following Table 1.

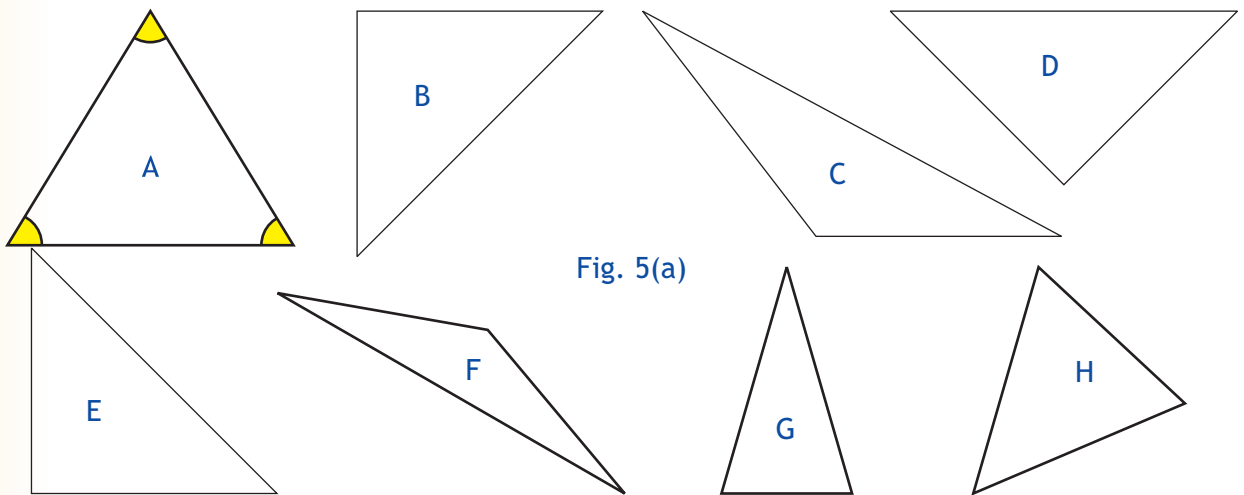

Fig. 5(a)

Table 1

Triangle	Number of Acute angles	Number of Right angles	Number of Obtuse angles
A	3	0	0
B			
C			
D			
E			
F			
G			
H			

### On the basis of sides

**Step 4.** Measure length of each side of each triangle. [Fig. 5(a)]

**Step 5.** Put a tick mark (✓) in the appropriate column in the following table.

**Table 2**

Triangle	All three sides are equal	Only two sides are equal	None of the side is equal
A			
B			
C			
D			
E			
F			
G			
H			

**Observations :** In Table 1 and 2 :

1. Triangles having three acute angles are ..... angled triangles.
2. Triangles having one right angle are ..... angled triangles.
3. Triangles having one obtuse angle are ..... angled triangles.
4. Triangles having three equal sides are ..... triangles.
5. Triangles having two equal sides are ..... triangles.
6. Triangles having all three sides of different lengths are ..... triangles.
7. Triangles which are right angled as well as isosceles are .....
8. Is there any triangle which has two right angles? .....
9. Is there any equilateral triangle which is also right angled or obtuse angled? .....
10. Is there any equilateral triangle which is also right angled or obtuse angled?

# 6

## ACTIVITY 6

To make the following shapes using a pair of set squares.

- (i) square
- (ii) rectangle
- (iii) parallelogram
- (iv) rhombus
- (v) trapezium.

**Objective** : Handling set squares.

**Pre-requisite** : Knowledge of geometrical shapes.

**Materials Required** : Two pairs of set squares, pencil/pe and paper.

**Procedure** : (i) Making a square shape.

**Step 1.** Take two  $45^\circ - 45^\circ - 90^\circ$  set squares and place them on a paper such that their longest-edges completely touch each other. [Fig. 6(a)]

**Step 2.** Now mark the boundary of the shape by moving a pencil around the outer edges of the set squares [Fig. 6(b)].

**Step 3.** See carefully the shape formed. It is a square.

**Procedure** : (ii) Making a rectangle

Take two  $30^\circ - 60^\circ - 90^\circ$  set squares and repeat the Steps 1, 2 and 3 mentioned above. Observe the shape formed. [Fig. 6(b) and 6(d)]

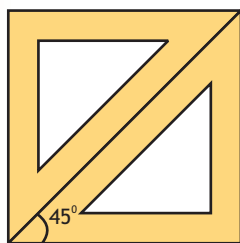

Fig 6(a)

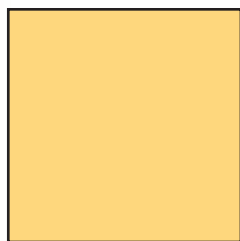

Fig 6(b)

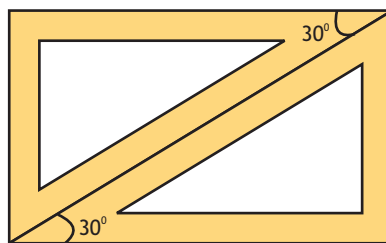

Fig 6(c)



Fig 6(d)

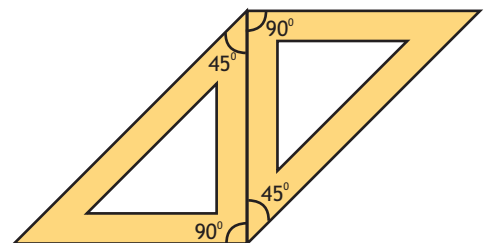

Fig 6(e)

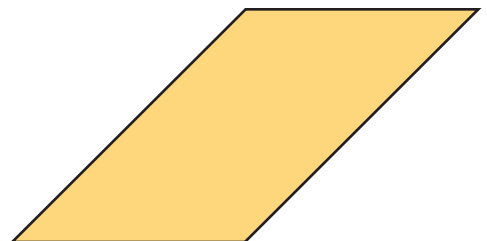

Fig 6(f)

**Procedure :** (iii) Making a parallelogram

**Step 1.** Take two  $45^\circ-45^\circ-90^\circ$  or  $30^\circ-60^\circ-90^\circ$  set squares.

**Step 2.** Place them such that  $90^\circ$  corner of the one set square is in contact with  $45^\circ$  corner of the other set square. [Fig 6(e)]

Mark the boundary and observe the shape formed. [Fig. 6(f)]

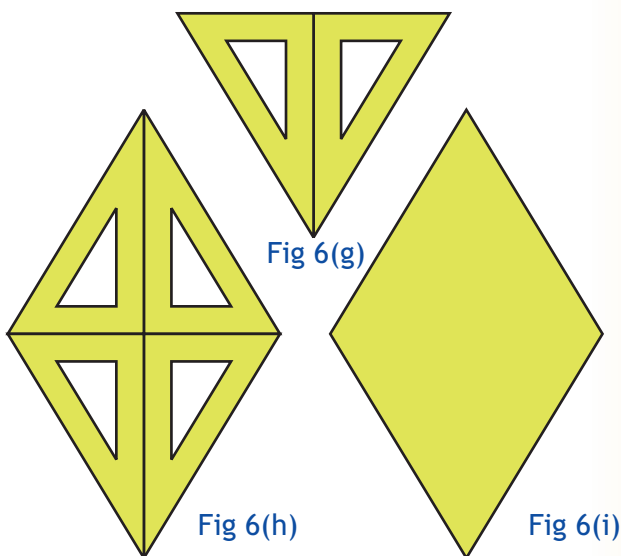

**Procedures :** (iv) Making a rhombus.

**Step 1.** Take two  $30^\circ-60^\circ-90^\circ$  set squares and place them to make an equilateral triangle [Fig. 6(g)].

**Step 2.** Make another equilateral triangle with same base by the same process opposite to first triangle as in [Fig. 6(h)].

**Step 3.** Mark the boundary and observe the shape so formed [Fig6(i)].

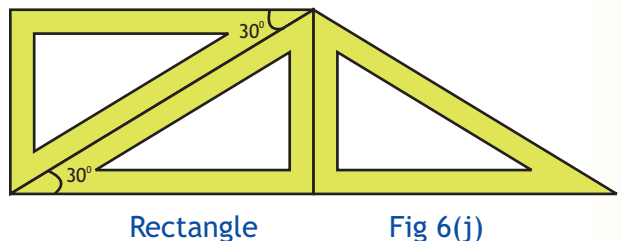

**Procedure :** (v) Making a trapezium.

**Step 1.** Make a rectangle using two identical set squares.

**Step 2.** Now place one more set squares of the shape size in contact with one side of the rectangle obtained [Fig. 6(j)].

**Step 3.** Mark the boundary and identify the four sided shape so formed. [Fig. 6(k)]

**Observations:**

(i) Shape formed in Fig. 6(b) is a .....

(ii) Shape formed in Fig. 6(d) is a .....

(iii) Shape formed in Fig. 6(f) is a .....

(iv) Shape formed in Fig. 6(i) is a .....

(v) Shape formed in Fig. 6(k) is a .....

(vi) No. of set squares used in making -

a square = ..... a rhombus = .....

a trapezium = ..... a parallelogram = .....

a rectangle = .....

# 6

## ACTIVITY 7

*To make a prism and a pyramid using their nets and to find their number of vertices, edges and faces.*

**Learning Objective :** To visualise 3 dimensional shapes, namely, a prism on a triangular base (triangular prism) and a pyramid on a triangular base (tetrahedron).

**Pre-requisite :** Knowledge of solid shapes specially a prism a pyramid knowledge of vertices, edges and faces of 3-D object.

**Materials required :** Cut out of nets of a prism and a pyramid on triangular base, glue, pencil.

**Procedure :**

**Step 1.** Take the cut out of the net shown in Fig. 7(a) and fold it along the dotted lines.

**Step 2.** Apply gum on the flaps and join to give the shape shown in Fig. 7(b).

**Step 3.** Count the number of vertices, edges and faces of this shape.

**Step 4.** Take the cut out of the net shown in [Fig. 7(c)] and fold it along the dotted lines.

**Step 5.** Follow again Steps 2 and 3 to obtain a 3-D object (triangular pyramid or tetrahedron) as shown in Fig. 7(d).

**Step 6.** Count the number of vertices, edges and faces of this shape.

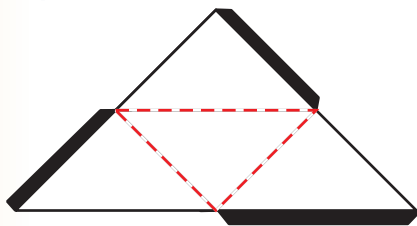

Fig 7(c)

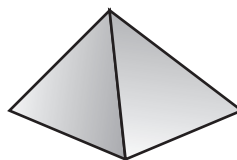

Fig 7(d)

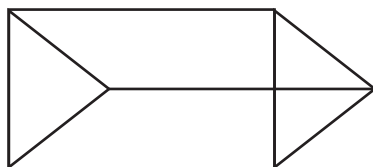

Fig 7(b)

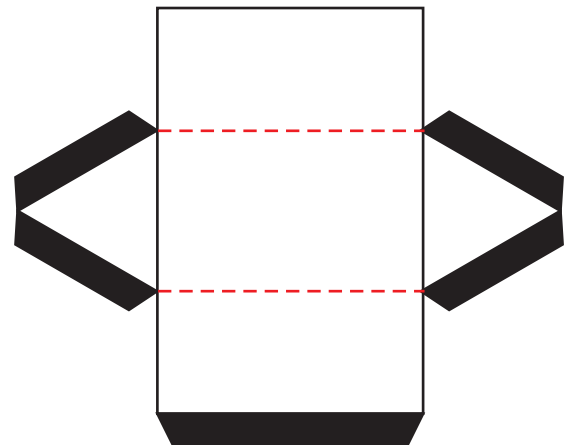

Fig 7(a)

**Observations :**

- Solid obtained in Fig 7(b) is a prism with ..... base.
- Solid obtained in Fig. 7(d) is a ..... with ..... base.
- Complete the following table.

Solid	Number of Vertices	Number of edges	Number of faces
Triangular Prism			
Triangular Pyramid			



## ACTIVITY 8

To perform addition and subtraction of integers using different coloured buttons/counters.

**Learning Objective** : To understand the concepts of addition and subtraction of integers.

**Prerequisite** : Familiarity with integers.

**Materials required** : 10 white buttons and 10 black buttons.

**Procedure :**

**Step 1.** Assume a white button as (+1), a black button as (-1) and a pair of one white and one black button as zero [Fig. 8(a)].

**Step 2.** To find the sum of  $(+5) + (-2)$ , take 5 white buttons and 2 black buttons and arrange them in two rows as shown in the [Fig. 8(b)].

**Step 3.** Match one white button with one black buttons as shown in Fig. 8(c).

**Step 4.** Every pair of one white and one black button makes zero. Count the remaining buttons and note down their colour. If remaining buttons are white, answer is a positive integer. If remaining buttons are black, answer is a negative integer.

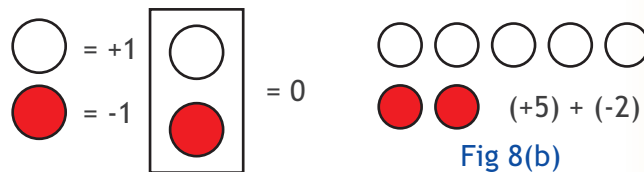

Fig 8(a)

Fig 8(b)

**Step 5.** To find the value of  $(+4) + (-6)$ , take 4 white buttons and 6 black buttons. [Fig. 8(d)].

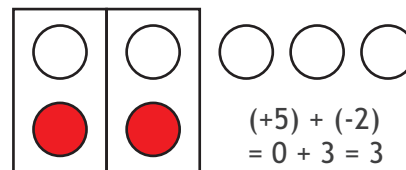

Fig 8(c)

**Step 6.** Follow the Steps 2 to 4. [Fig. 8(e)]

**Step 7.** To find the value of  $(+5) - (+2)$ , take five white buttons and 2 black buttons. [Since +2 is to be subtracted] and place them in 2 rows as shown in Fig. 8(f).

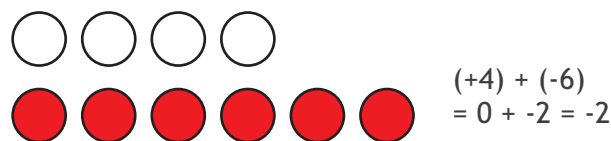
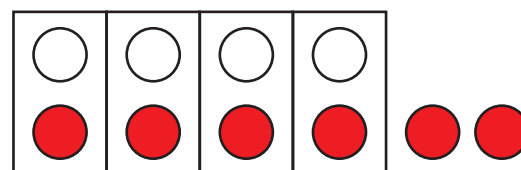

Fig 8(d)

**Step 8.** To subtract +2 means adding -2 i.e. 2 buttons of black colour. Match the button of two colours [Fig. 8(g)]



$$(+4) + (-6) = 0 + (-2) = -2$$

Fig 8(e)

**Step 9.** Count the remaining buttons and note their colour.

**Step 10.** To find the value of  $(+4) - (+5)$  take four white buttons and 5 black buttons. Arrange them in rows as shown in Fig. 8(h). Match the buttons of two colours.

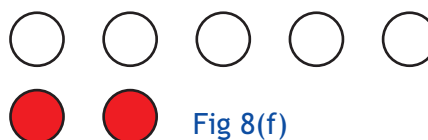

Fig 8(f)

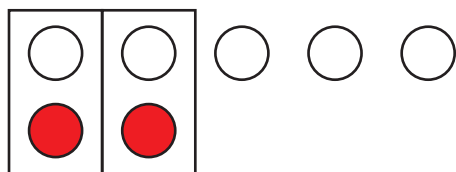

Fig 8(g)

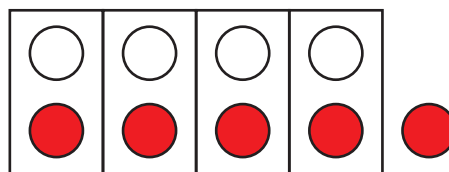

Fig 8(h)

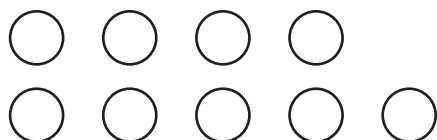

Fig 8(i)

**Step 11.** To find value of  $(+4) - (-5)$ , take four white buttons and 5 white buttons and place them in 2 rows as shown in Fig. 8(i). Count the number of buttons and their colour.

**Observations:**

- (i) In Step (4), the number of remaining buttons = .....  
 Their colour is .....
- So,  $(+5) + (-2) = \dots\dots\dots$
- (ii) In Step 6, the number remaining buttons = .....  
 Their colour is .....
- So,  $(+4) + (-6) = \dots\dots\dots$
- (iii) In Step 8, the number of remaining buttons = .....  
 Their colour is .....
- So,  $(+5) - (+2) = \dots\dots\dots$
- (iv)  $(+4) - (+5) = \dots\dots\dots$
- (v)  $(+4) - (-5) = \dots\dots\dots$

## ACTIVITY 9

To represent decimal numbers 0.25, 0.5, 0.75, 0.68 etc. using a 10x10 grid.

**Learning Objective :** To understand decimals.

**Pre requisite :** Knowledge of of fractions and decimals.

**Materials required :** Grid paper and coloured pens.

**Procedure :**

**Step 1.** Take a 10x10 grid and shade 25 unit squares. The shaded portion represents  $25/100$  i.e. 0.25 [Fig. 9(a)]. **Can you represent 0.25 in some other way on a 10x10 grid?**

**Step 2.** To represent 0.5 means to represent 0.50. Take a 10 x 10 grid and shade 50 unit squares. The shaded portion represents  $50/100$  i.e. 0.50 or 0.5 [Fig. 9(b)].

**Step 3.** Try to represent other decimal numbers.

**Observations :**

- (i) The number of unit squares in the grid in Fig. 9(a) = .....
- (ii) The number of unit squares shaded in Fig. 9(a) = .....
- (iii) The shaded portion in Fig. 9(a) represents the decimal .....
- (iv) The shaded portion in Fig. 9(b) represents the decimal .....

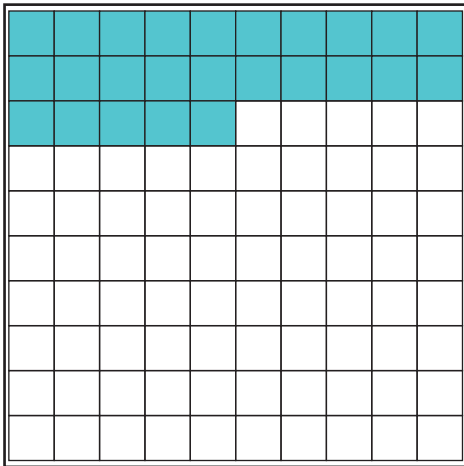

Fig. 9(a)

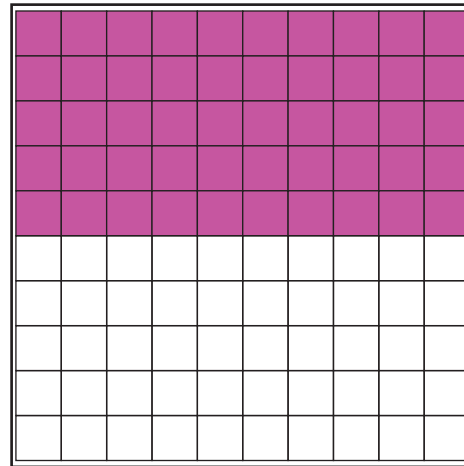

Fig. 9(b)



# 6

## ACTIVITY 10

### Group Activity

(a) To find the areas of palm impressions on a grid paper of each group member, by counting the squares.

(b) To represent the data so obtained by means of a bar graph.

**Learning Objective** : (1) To find approximate area of irregular shapes.

(2) To represent the given data through bar graph.

**Pre-requisite** : Concept of area, representation of data through a bar graph.

**Materials Required** : A squared grid paper, coloured pencil, a pencil/pen and graph paper.

**Procedure** : (A)

**Step 1.** Each member of a group of students places the palm of his/her right hand on the squared grid paper, then moves the pencil around his/her palm to trace the boundary. [Fig. 10(a)].

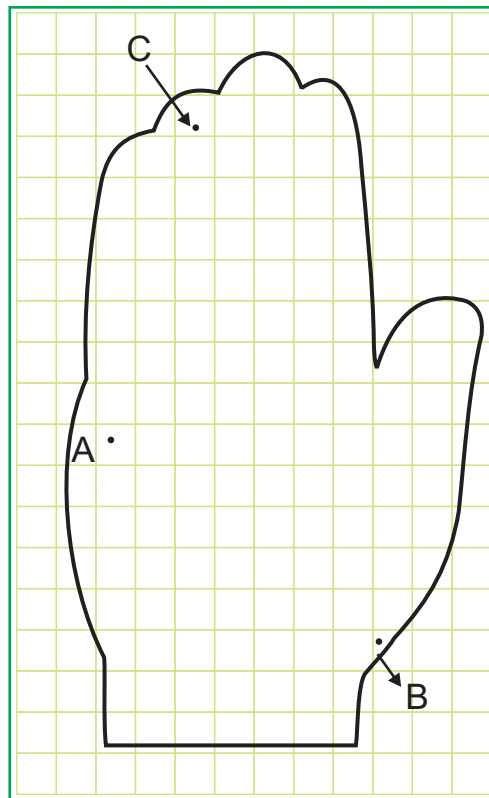

Fig 10(a)

**Step 2.** Count the number of squares enclosed in the boundary by taking half as half, more than half as 1 and leaving the others (i.e less than half).

**Step 3.** Each group member records the data in the following table. Number of squares inside the palm impression is the area of the palm impression.

Group Member	Number of squares (half or more than half)	Area in square units
1	110	110
2		
3		
4		
5		

**Procedure : (b)**

**Step 4.** Take a graph paper. Draw two lines, one horizontal and one vertical as shown in Fig.10(b).

**Step 5.** Along the horizontal line, write the names of students at equal distances as shown in Fig. 10(c)

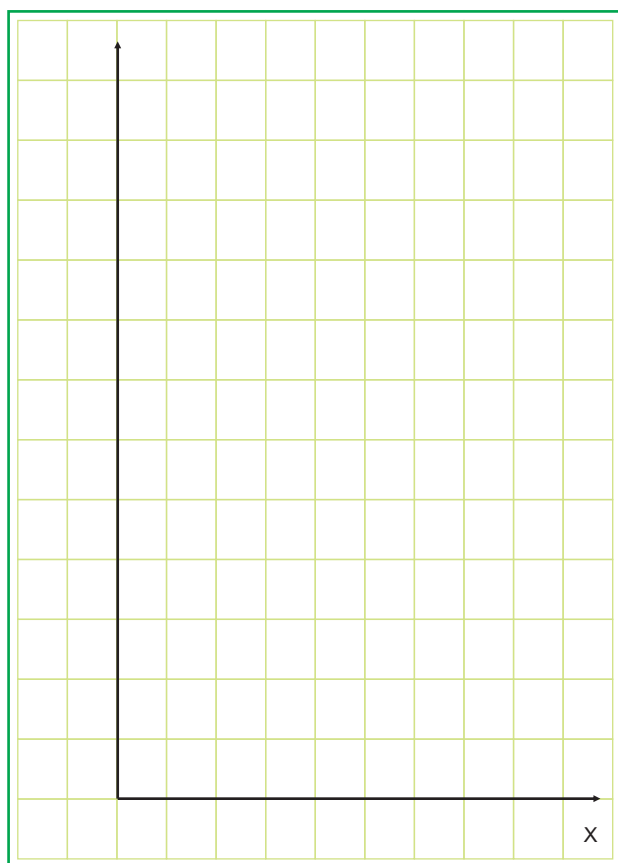

Fig 10(b)

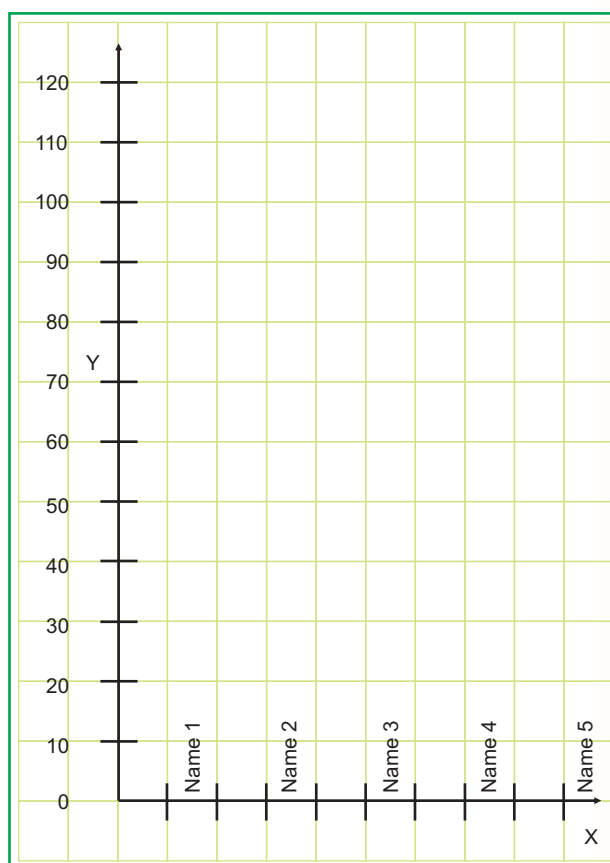

Fig 10(c)

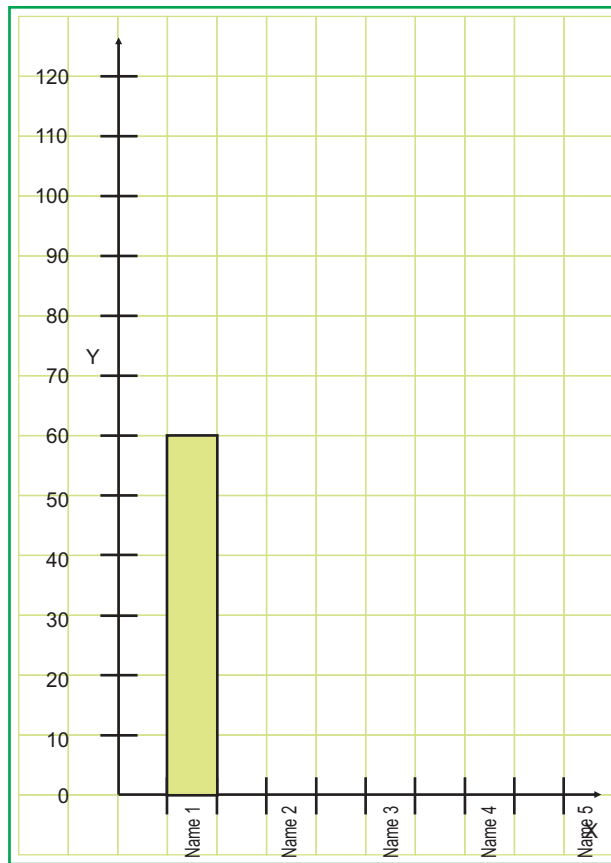

Fig 10(d)

- Step 6.** Along the vertical line, write numbers from 0 till 120 at equal distances as shown in [Fig. 10(c)]
- Step 7.** Let us consider Name 1 and let the area of his/her palm impression is 60 squares. On name 1, draw the bar of height 60 [Fig. 10(d)].
- Step 8.** Similarly, draw the bar corresponding to the data obtained for other group members.

**Observations:**

- (i) Which member of the group has the maximum palm area? .....
- (ii) Which member of the group has the minimum palm area? .....
- (iii) Which of the group members have the same palm area? .....

**Extension :**

- 1. The activity can be used to find the area of any irregular shape. Draw and trace different shapes and find their areas.
- 2. Collect different types of data, for example, total number of students in each class (may be from VI to VIII) or different sections of a class; number of scores obtained by different houses in a school activity, etc. Represent the data in the form of bar graph.

## ACTIVITY 11

To determine the number of lines of symmetry of following shapes by paper folding -

- (a) equilateral triangle
- (b) isosceles triangle
- (c) square
- (d) rectangle
- (e) rhombus

**Learning Objective :** To understand line symmetry of plane figures and draw their lines of symmetry.

**Pre-requisite :** Knowledge of line symmetry of plane figures.

**Materials Required :** Cutouts of the geometrical figures, equilateral triangle, isosceles triangle square, rectangle and rhombus.

**Procedure:**

**Step 1.** Take a cutout of an equilateral triangle. Fold it through a vertex so that the two parts of the triangle cover each other exactly, Fig 11(a).

**Step 2.** Unfold and mark the crease or the line of fold. The triangle is said to have a symmetry called line symmetry. This line of fold is called a line of symmetry of the triangle.

**Step 3.** Fold the triangle again in the same way through other two vertices Fig. 11(b) to get two more lines of symmetry.

**Step 4.** Now take a cutout of an isosceles triangle and follow Steps 1 and 2 above. Mark the line of symmetry, if any.

**Step 5.** Repeat the activity by taking cut out of a square, a rectangle and a rhombus. Mark lines of symmetry in each case, if any.

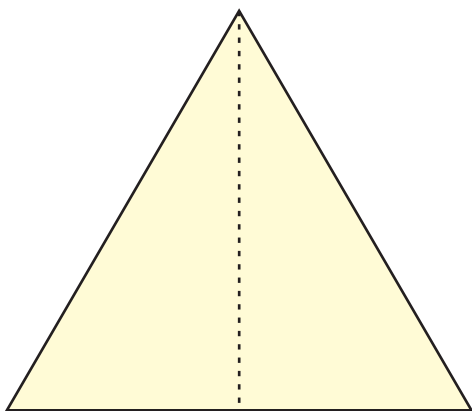

Fig 11(a)

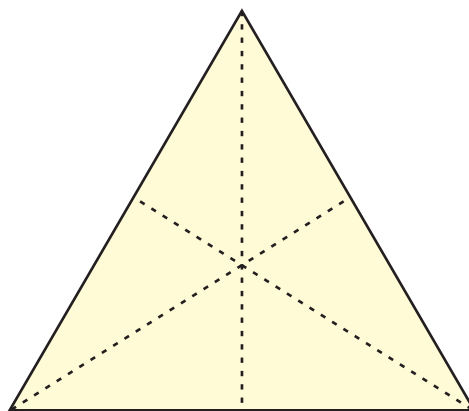
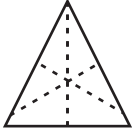

Fig 11(b)



**Observations :** Complete the following table :

Figure	Lines of Symmetry	Number of Lines of Symmetry
Equilateral triangle		3
Isosceles triangle		.....
Square		.....
Rectangle		.....
Rhombus		.....

**Extension :** Taking cutouts of some other plane figures, try to find lines of symmetry, if they have any.



**ACTIVITY 12**

*To collect the data from the students regarding time spent (more than 2 hours) in watching T.V. and to present the data in the form of a bar graph by paper cutting and pasting.*

**Learning objective** : To collect data and to represent data in the form of a bar graph.

**Pre-requisite** : Knowledge of drawing a bar graph

**Materials required** : Coloured and white papers, sketch pens, a pair of scissors, a pencil and glue.

**Procedure :**

**Step 1.** Record the number of hours spent by each student in the class during a day in watching TV in Table 1.

**Table 1**

Name of student	Number of hours spent in watching TV

**Step 2.** List the student who spent more than 2 hours a day in watching TV in Table 2.

**Table 2**

Name of student	Number of hours (more than 2) spent in watching TV

**Step 3.** To make a bar graph of the data in Table 2, draw two lines (one horizontal and one vertical as shown in Fig. 12(a).

**Step 4.** Write the names of the students in Table 2 along the horizontal line at equal distances and time spent (in hours) along the vertical line. [Fig. 12(b)]

**Step 5.** Now make strips of uniform width of different colours, for each students, of length according to time (in hour) spent by him/her in watching TV (see Table 2).

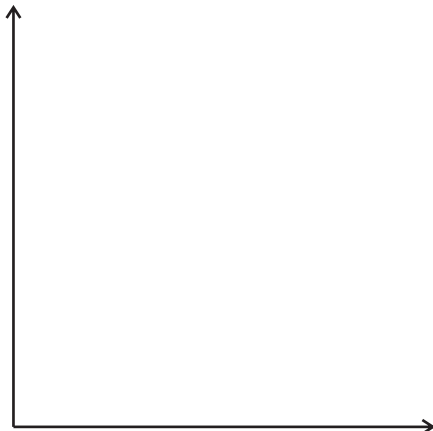
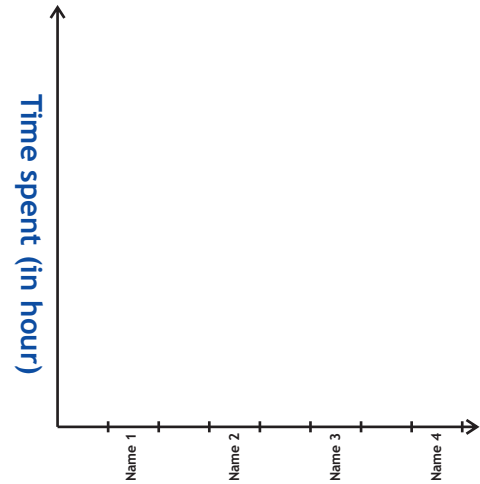

Fig. 12(a)



Name of students

Fig. 12(b)

**Step 6.** Paste these strips in Fig. 12(b) accordingly against the names of the students.

**Observations :**

- (i) The numbers of students who spent 2 to 3 hours in watching TV a day = .....
- (ii) The name(s) of students who spent more than 6 hours a day watching TV are .....
- (iii) The name(s) of the student(s) who spent maximum time in watching TV are .....
- (iv) The name(s) of the student(s) who spent exactly 2 hours a day in watching TV is/are .....

**Extension :** Collect the data for other activities such as time spent in doing homework (in a week) by each student of your class and draw a bar graph for the data.